

Tool List

- 15/16" Open End Wrench
- 15/16" Socket
- 1/2" Socket
- 1/2" Ratchet
- Level
- Plumb Bob
- 7/32" drill bit
- Cordless drill
- Impact Driver

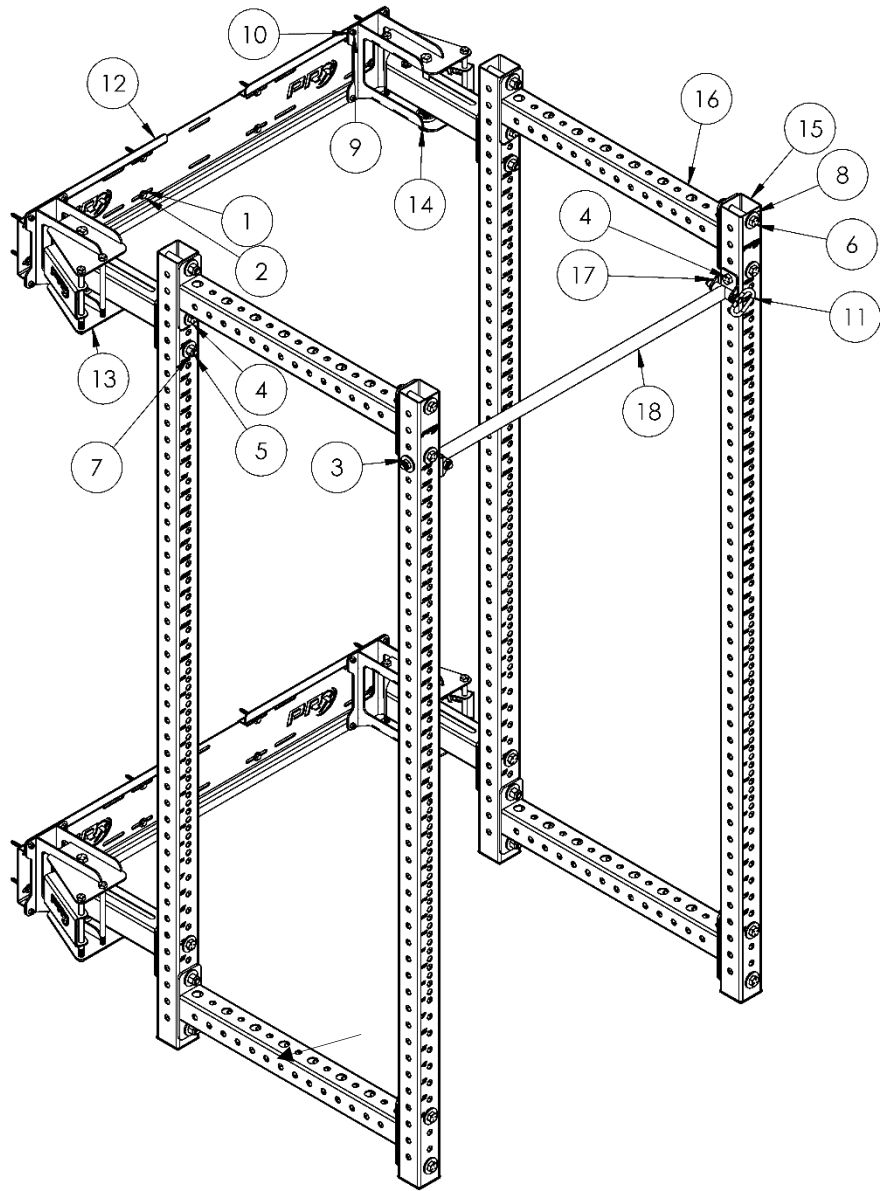

Item #	Description	Qty.
1	5/16" x 2" Lag Screw	16
2	5/16" Flat Washer	16
3	5/8" Thin Locknut	2
4	5/8" x 4" Hex Bolt	6
5	5/8" x 4-1/4" Hex Bolt	2
6	5/8" x 4-1/2" Hex Bolt	14
7	5/8" Hex Locknut	16
8	5/8" Flat Washer	34
9	5/16" x 3/4" Carriage Bolt	16
10	5/16" Hex Locknut	16
11	Grip Pin	1
12	Wall Bracket	2
13	Left Hinge	2
14	Right Hinge	2
15	3x3 Upright	4
16	Crossmember	4
17	Pull-Up Bar Pin Plate	1
18	Pull-Up Bar	1

WARNING

- Read all assembly, installation and use instructions in this manual prior to using this equipment.
- Keep body and clothing free from and clear of all moving parts
- Inspect equipment prior to use. DO NOT use if it appears damaged or inoperable
- Use equipment only for the intended use DO NOT modify the machine
- DO NOT attempt to fix broken equipment. Call or email PRx Performance for assistance.

Save this manual for future reference.

All questions, feedback, and return information should be sent to: support@prxperformance.com or call us at 1-701-566-0452

Getting Started

1. Assemble all tools listed on page 1 and clear your workspace.
2. **Check the stud spacing of your wall:** The Profile® Folding Full Cage is designed to be mounted to wood studs with standard 12", 16", or 24" spacing.
 - To mount your rack to a wall with non-standard stud spacing, please use a stringer board. If you have any questions about the stringer board, please email us at support@prxperformance.com.
 - PRx recommends professional installation for mounting the wall brackets to a block, concrete, or metal stud wall.
3. **Check your wall width:** Profile® Folding Full Cage requires 48" of wall space. Identify the studs you plan to mount your rack to and ensure you'll have 32" on both sides of your rack to allow space to use a barbell.
4. **Check your ceiling height:** Installation requires ceilings to be 2" taller than your upright.
5. **Check your floor slope:** The Profile® Folding Full Cage is designed so all four uprights sit on the floor when the floor is sloped less than 1/4" per foot. If your floor is sloped more than 1/4" per foot in any direction, please email us at support@prxperformance.com.
6. Recruit a work partner to assist with lifting and holding parts during assembly.

082923_REV. 1

Installation Instructions

Installing the Wall Brackets

1. Begin by determining if your floor slopes down to the left, down to the right, or is flat (**Figure 1**).
If the floor slopes down to the left or is flat, measure the far-left stud first. If the floor slopes down to the right, measure the far-right stud first.

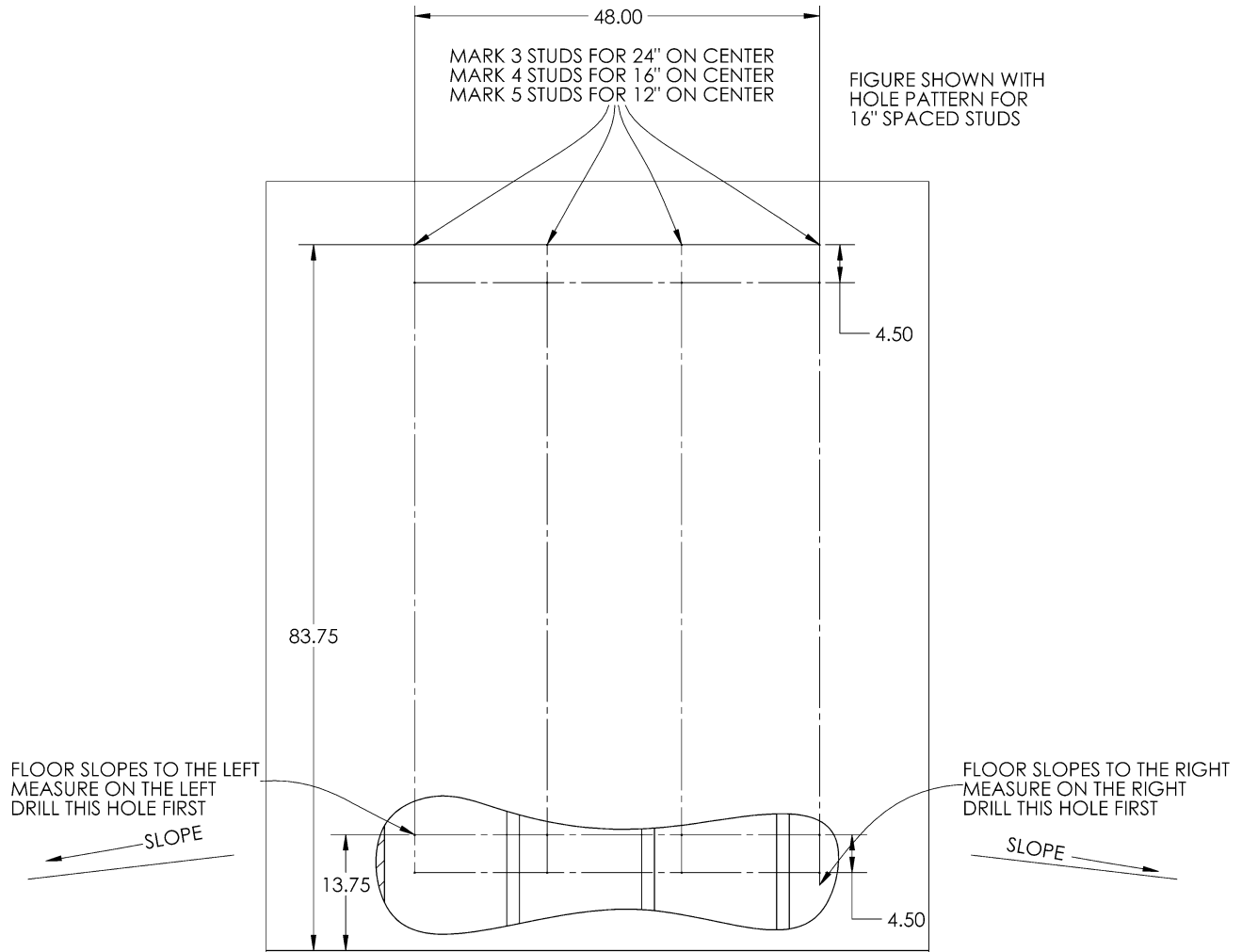

Figure 1. Stud and hole locations

2. Locate two studs spaced 48" apart, and all studs in between, using a stud finder (**Figure 1**).
3. Based on step 1, mark the first stud at 13-3/4" and the height depending on your upright height from the floor (**Figure 1**).
 - a. 95" Uprights = 89-3/4"
 - b. 89" Uprights = 83-3/4"
 - c. 81" Uprights = 75-3/4"

All questions, feedback, and return information should be sent to: support@prxperformance.com or call us at 1-701-566-0452

Installation Instructions

4. Use the cordless drill and the 7/32" drill bit to drill the marked holes 2-1/2" deep.
5. Using the 1/2" socket and the impact driver, install the upper wall bracket (12) with a 5/16" lag screw (1) and 5/16" flat washer (2) through the top hole of the wall bracket that is flush to the wall. Do not fully tighten the lag screw.
6. Place the level across the top of the upper wall bracket, level the wall bracket, and mark the opposite stud 48" away where it aligns with the top hole of the wall bracket that is flush to the wall.
7. Use the cordless drill and the 7/32" drill bit to drill the marked hole 2-1/2" deep.
8. Install the second 5/16" lag screw (1) and 5/16" flat washer (2) through the top hole of the wall bracket. Do not fully tighten the lag screws.
9. Level the wall bracket and fully tighten the two lag screws.
10. Drill pilot holes and install the rest of the upper wall bracket lag screws into the marked studs **(Figure 2)**.
11. Repeat steps 5-8 for the lower wall bracket, but do not fully tighten the lag screws.
12. Use a plumb bob to vertically align the upper and lower wall bracket edges. Once aligned and level, fully tighten the lag bolts in the lower wall bracket.
13. Drill pilot holes and install the rest of the lower wall bracket lag screws into the marked studs **(Figure 2)**.

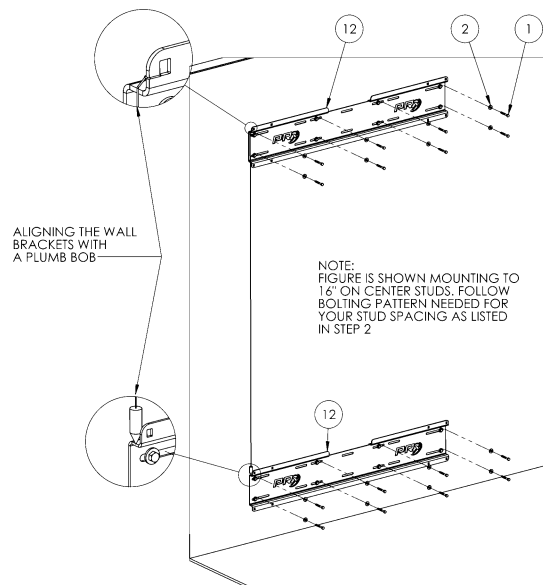

Figure 2: Installing the lag screws

All questions, feedback, and return information should be sent to: support@prxperformance.com or call us at 1-701-566-0452

Installing the Hinges

With the wall brackets installed, the hinges can now be attached. There are two left and two right hinges. Ensure the logo is oriented upward and facing out (**Figure 3**).

1. Using the 1/2" open end wrench, four 5/16" x 3/4" carriage bolts (9), and the four 5/16" lock nuts (10), attach one hinge to the wall bracket by inserting the carriage bolts from behind the wall bracket. Repeat this step for all upper and lower hinges.

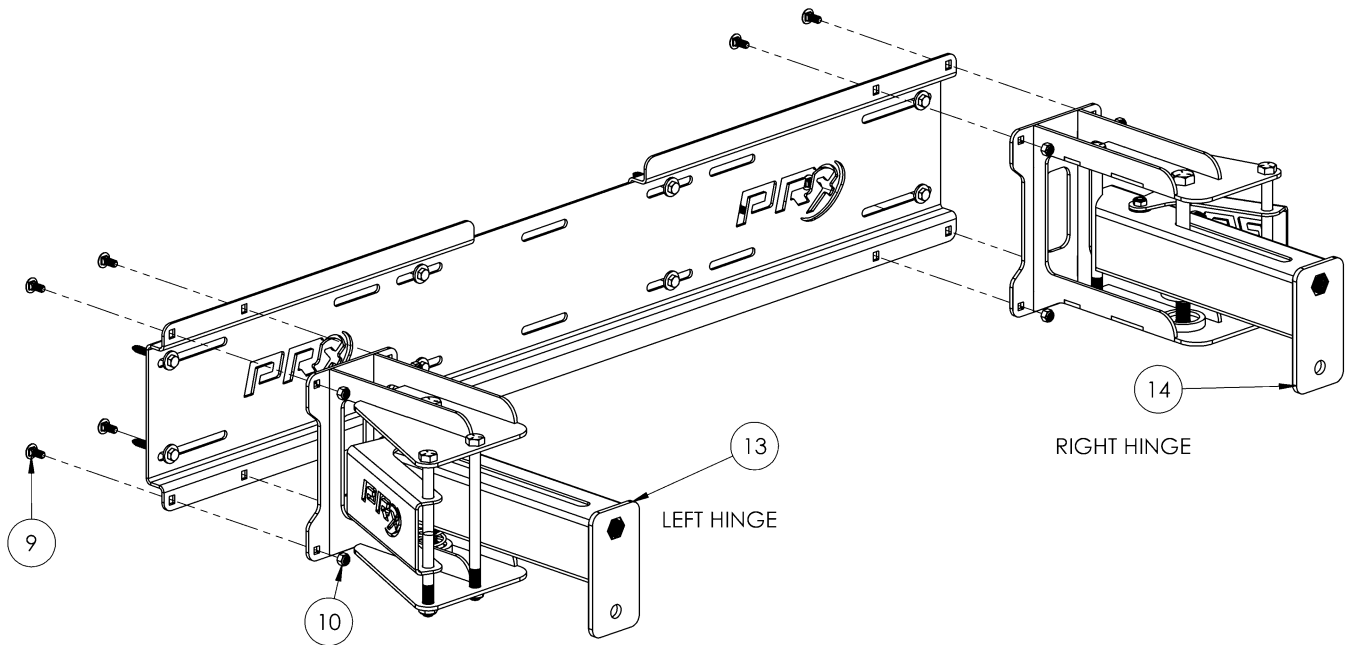

Figure 3: Mounting the hinges

All questions, feedback, and return information should be sent to: support@prxperformance.com or call us at 1-701-566-0452

! WARNING: SERIOUS INJURY OR DEATH COULD OCCUR IF SAFETY PRECAUTIONS ARE NOT TAKEN.

Installing The First Set of Uprights

1. Attach the first upright (15) to the hinge at the top using one 5/8" x 4-1/4" hex bolt (5) with one 5/8" lock nut (7) and one 5/8" flat washer (8) by bolting through the back of the upright.
2. Attach the first upright to the hinge at the bottom using one 5/8" x 4" hex bolt (4) and one 5/8" flat washer (8) at the bottom by bolting through the front of the upright (**Figure 4**).
3. Fully tighten both bolts with 15/16" wrench and socket wrench.
4. Repeat on the other side.

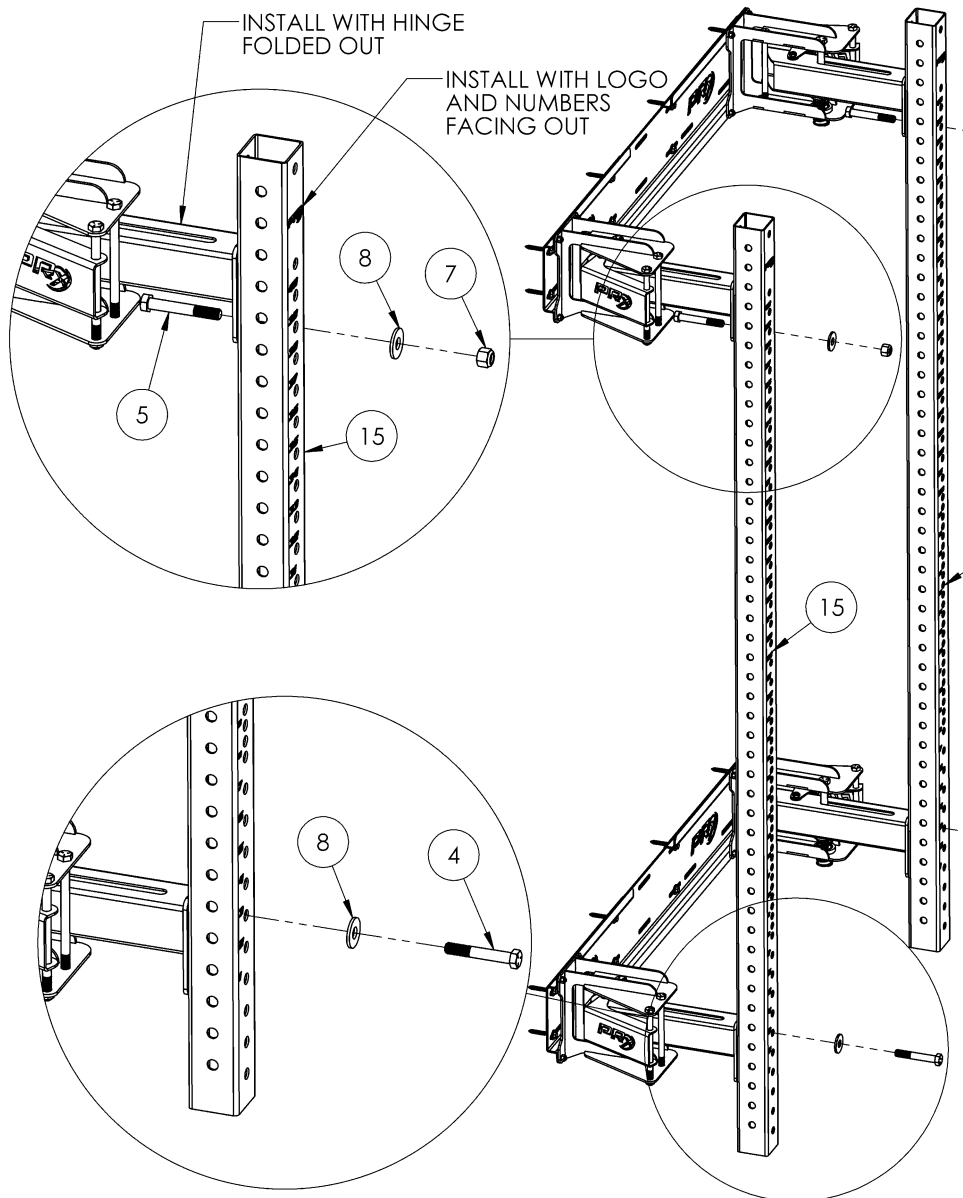

Figure 4: Attaching the first set of uprights

All questions, feedback, and return information should be sent to: support@prxperformance.com or call us at 1-701-566-0452

Attaching the Crossmembers

1. With the help of another person, bolt on the four crossmembers (16) following **Figure 5** closely.
2. Install the upper crossmembers by inserting the 5/8" x 4" hex bolt (4) and 5/8" flat washer (8) from the crossmember side into the hinge. This bolt only needs one washer.
3. Then insert the 5/8" x 4-1/2" hex bolt (6) with two 5/8" flat washers (8) and nut (7) through the back side of the upright.
4. Install the lower crossmember by inserting two 5/8" x 4-1/2" hex bolts (6) with 5/8" flat washers (8) and 5/8" lock nuts (7) through the back side of the upright. The top bolt should also connect through the hinge. This bolt only needs one washer.

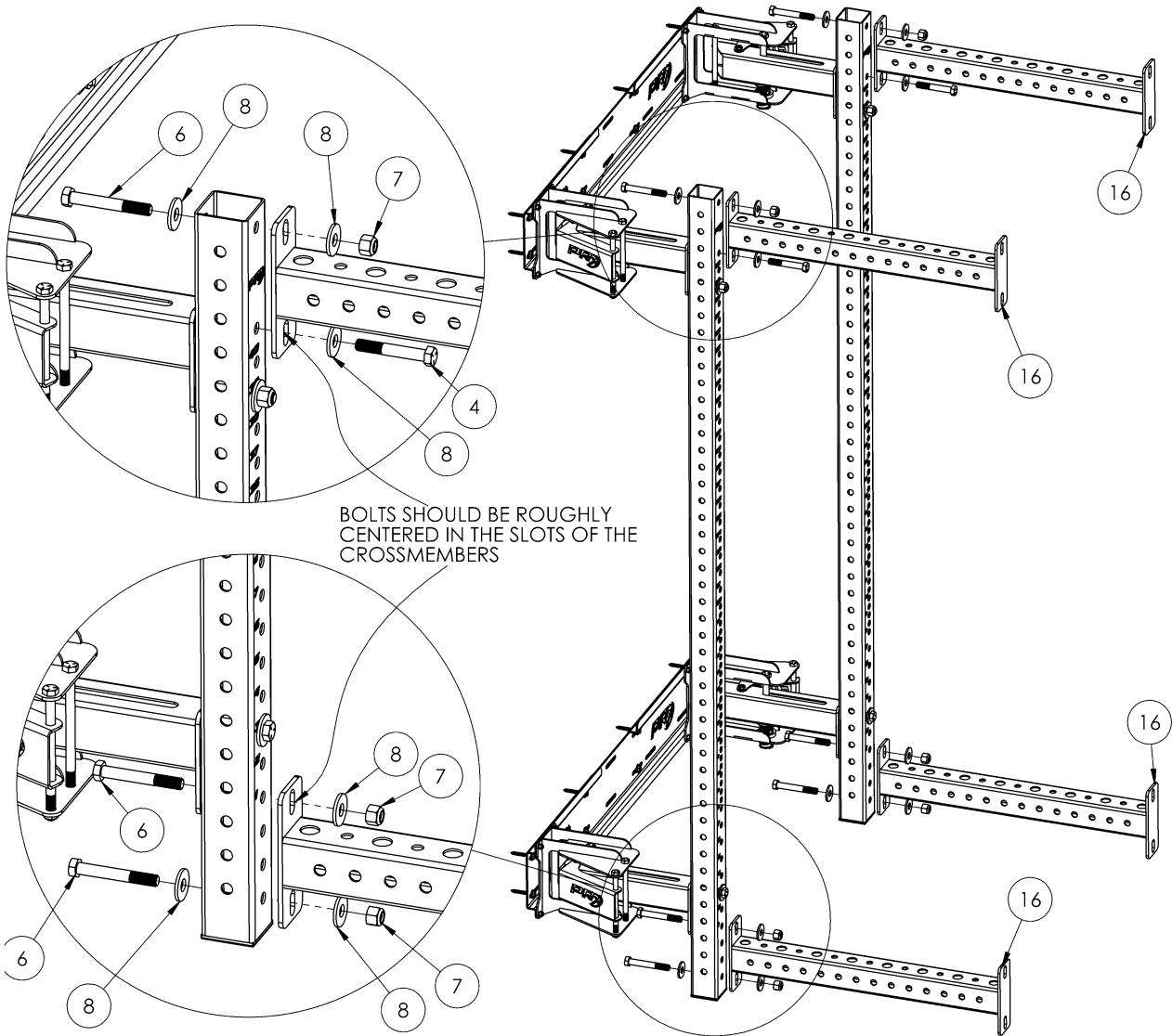

Figure 5: Attaching the crossmembers

All questions, feedback, and return information should be sent to: support@prxperformance.com or call us at 1-701-566-0452

Attaching the Front Uprights

1. With the help of another person, attach the remaining two front uprights (15) (**Figure 6**).
2. For each upright, install two 5/8" x 4 1/2" hex bolts (6), four 5/8" flat washers (8), and two 5/8" locknuts (7) through each crossmember.
3. Before tightening the bolts on the front upright, make sure that all four uprights are pressed down and touch the floor.
4. Fully tighten all crossmember bolts.

Note: If the front upright does not contact the floor when the rear upright is pushed down to the ground, loosen the rear crossmember bolts to allow the crossmembers to slide down further. If all four feet of your rack are still not touching the floor when folded out, please check your wall bracket measurements.

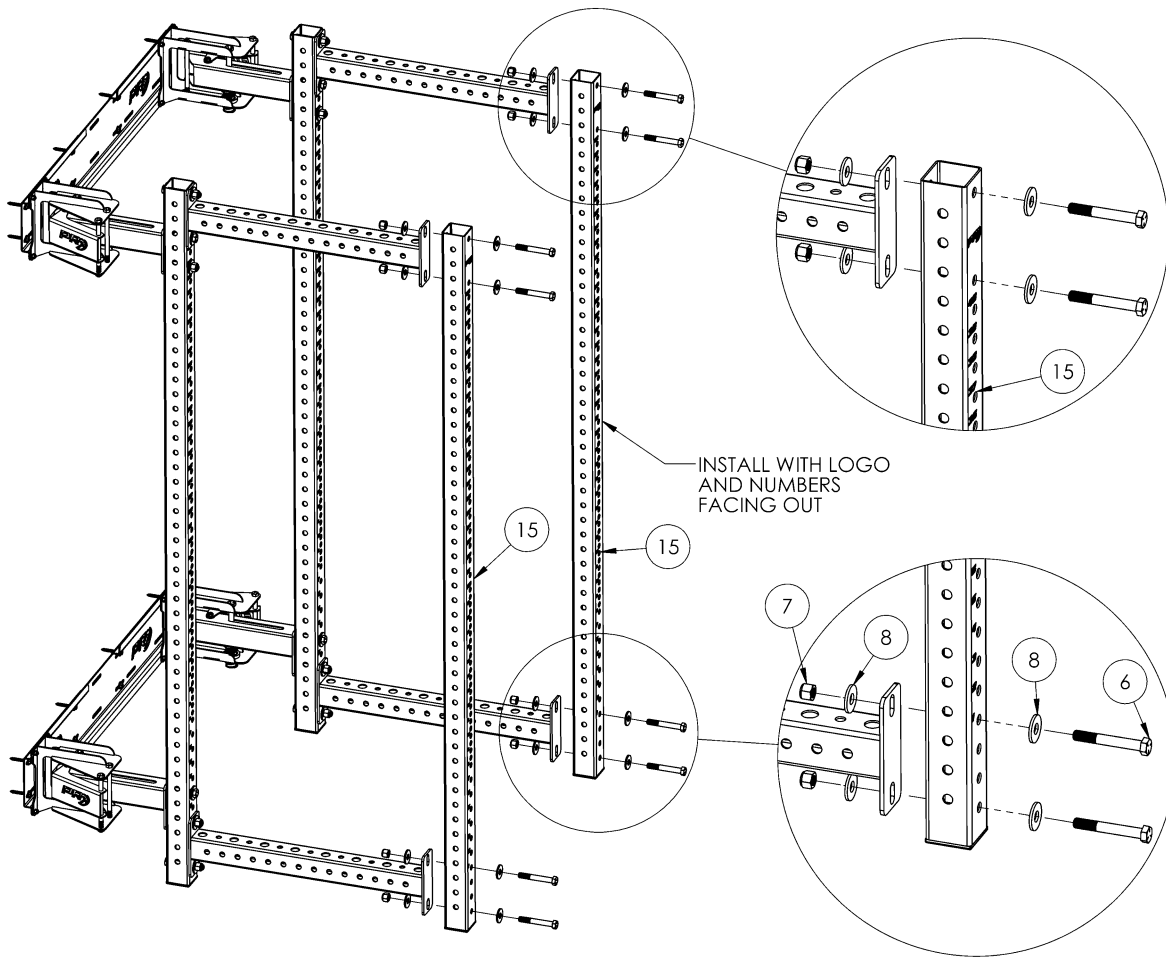
**Figure 6: Attaching the second set of uprights**

All questions, feedback, and return information should be sent to: support@prxperformance.com or call us at 1-701-566-0452

Installation Instructions

Installing the Pull-Up Bar

1. With the 15/16" open end wrench and 15/16" socket wrench, attach the pull-up bar (18) to the rack using a 4" x 5/8" Hex bolt (4), a 5/8" flat washer (8), and a 5/8" thin locknut (3) below the crossmember bolt (**Figure 7**).

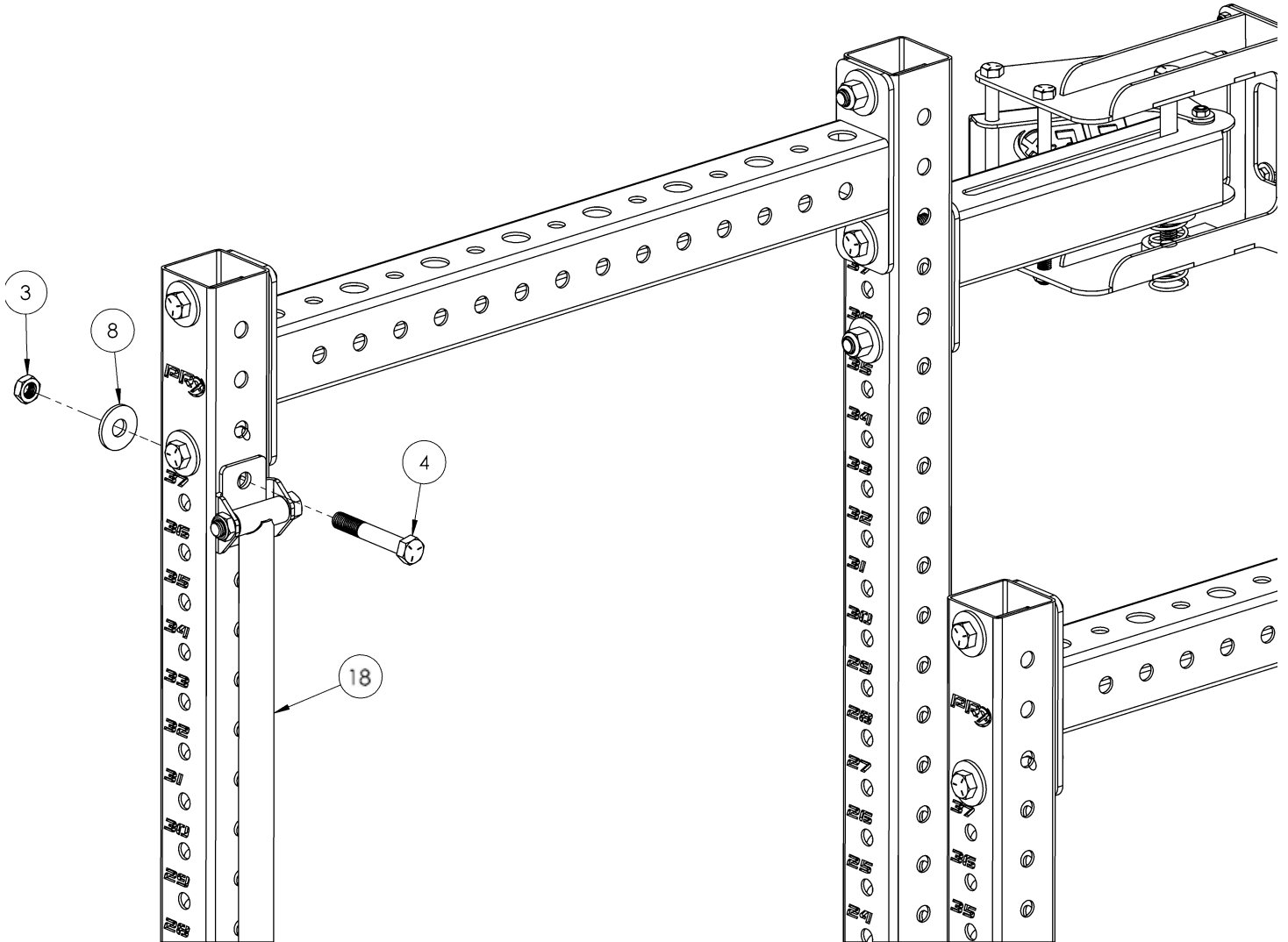

Figure 7: Attaching the pull-up bar to the rack

All questions, feedback, and return information should be sent to: support@prxperformance.com or call us at 1-701-566-0452

! WARNING: SERIOUS INJURY OR DEATH COULD OCCUR IF SAFETY PRECAUTIONS ARE NOT TAKEN.

Installation Instructions

2. Attach the Pull-Up bar Pin Plate (17) to be even with the opposite pull-up bar bracket using a 4" x 5/8" Hex bolt (4), a 5/8" flat washer (8), and a 5/8" thin locknut (3) (**Figure 8**).

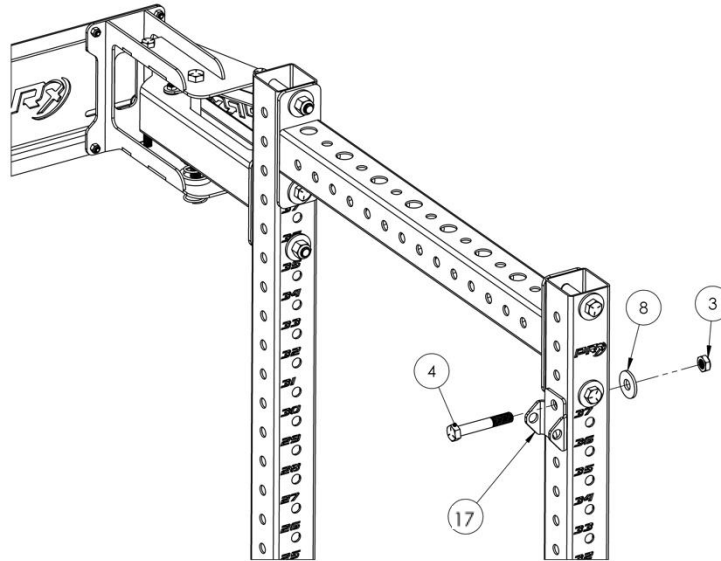

Figure 8: Bolting on the Pull-Up Bar Pin Plate

3. To use the pull-up bar, insert the Grip Pin (11) through the pin plate and pull-up bar. This pin functions as the locking mechanism for the rack and will need to be removed before folding (**Figure 9**).

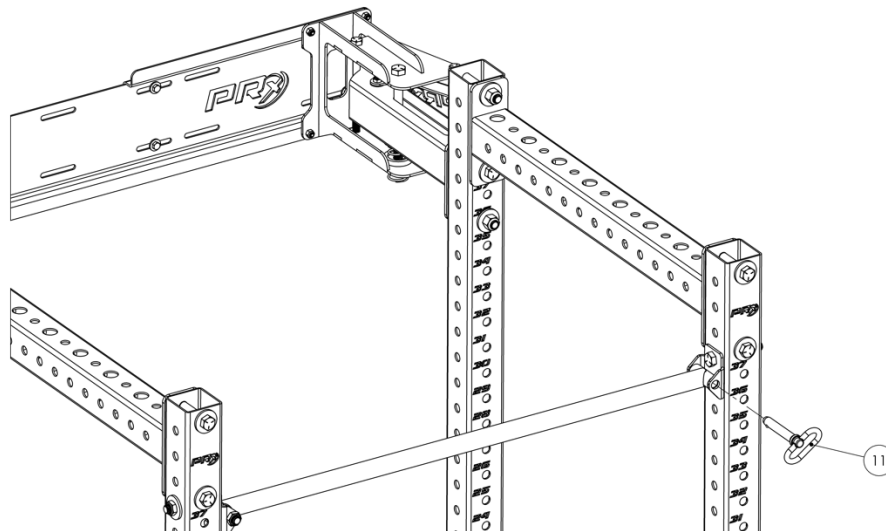

Figure 9: Using the pull-up bar

All questions, feedback, and return information should be sent to: support@prxperformance.com or call us at 1-701-566-0452