

OVERHEAD TRICEPS (PL-PV2-OTP)



POWER LEVERAGE **V2**

INSTALLATION MANUAL

 WWW.MUSCLEDFIT.COM

39/49 PIECES

OVERHEAD TRICEPS (PL-PV2-OTP)



No.	Name	Unit	Qty.
1	main frame	pcs	1
2	base component	pcs	1
3	seat component	pcs	1
4	weight pegs component	pcs	1
5	tension springs	pcs	1
6	springs	pcs	1

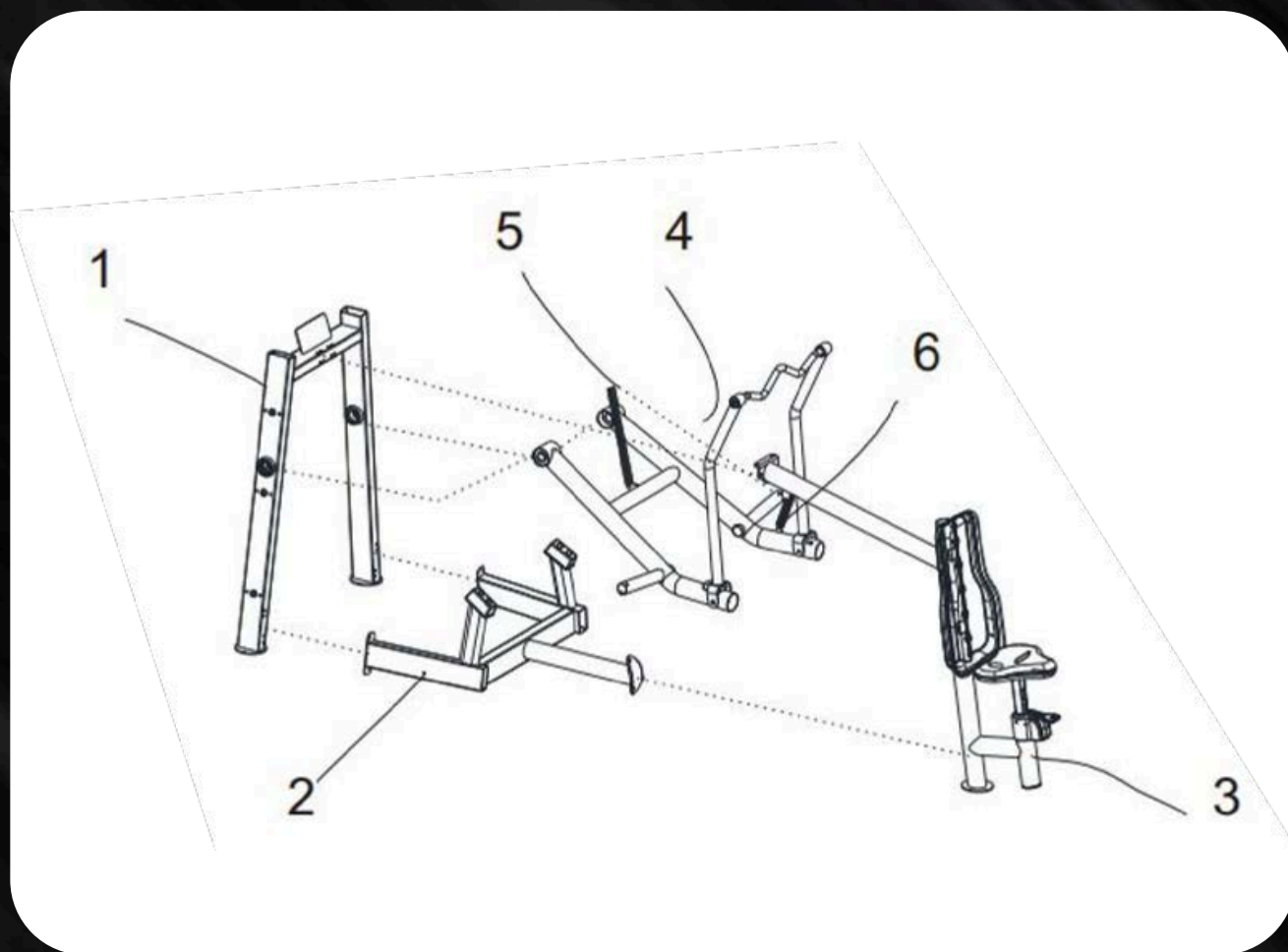

INSTALLATION MANUAL

POWER
LEVERAGE **V2**

 WWW.MUSCLEDFIT.COM