

HAMMER GRIP TRICEPS (PL-PV2-HGT)



POWER LEVERAGE **V2**

INSTALLATION MANUAL

 WWW.MUSCLEDFIT.COM

38/49 PIECES

HAMMER GRIP TRICEPS (PL-PV2-HGT)



No.	Name	Unit	Qty.
1	right frame component	pcs	1
2	left arm component	pcs	1
3	seat component	pcs	1
4	base component	pcs	2
5	base connector component	pcs	1

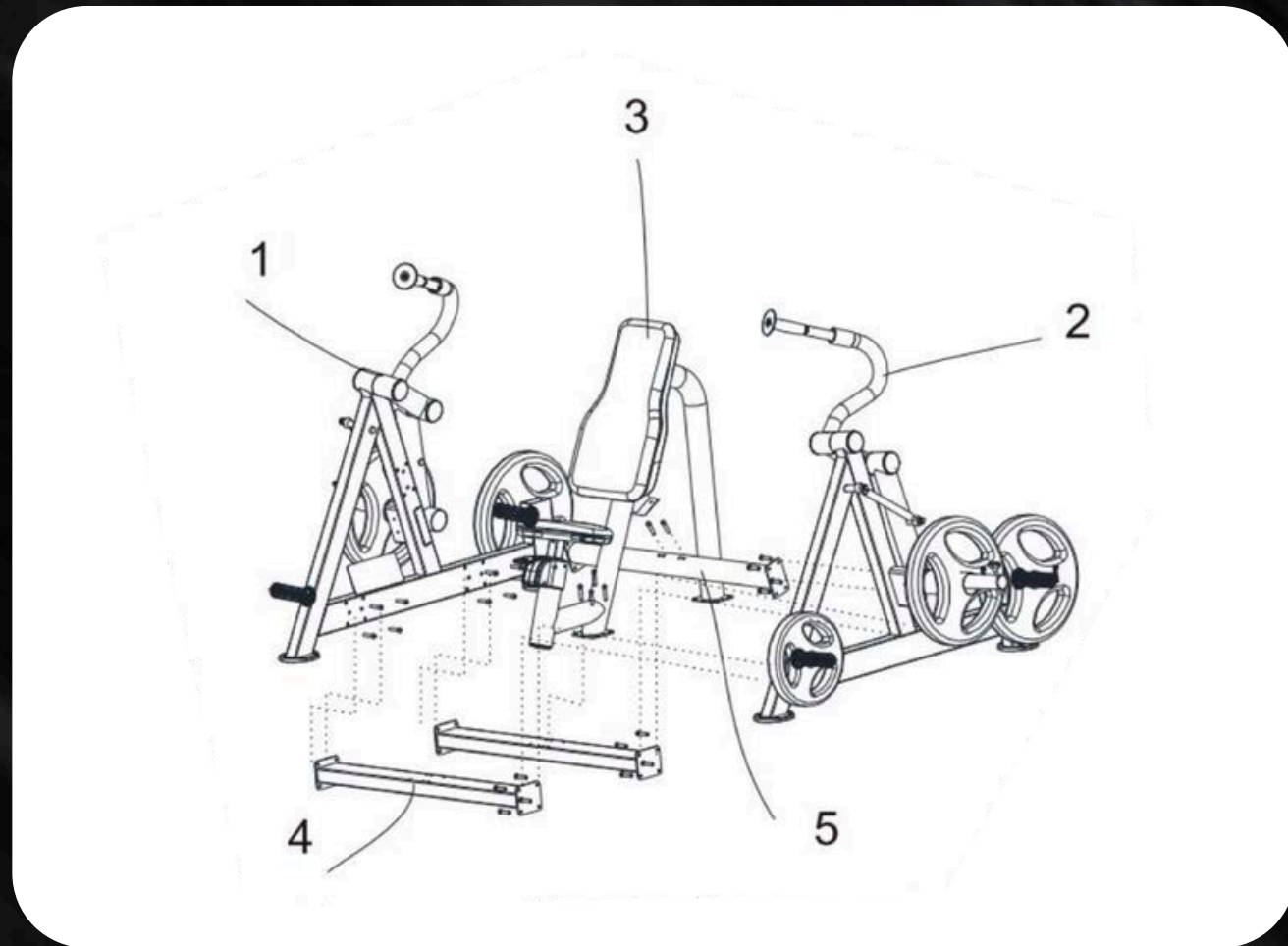

INSTALLATION MANUAL

POWER
LEVERAGE **V2**



WWW.MUSCLEDFIT.COM