

MEGATRON MULTI-FUNCTIONAL TRAINER

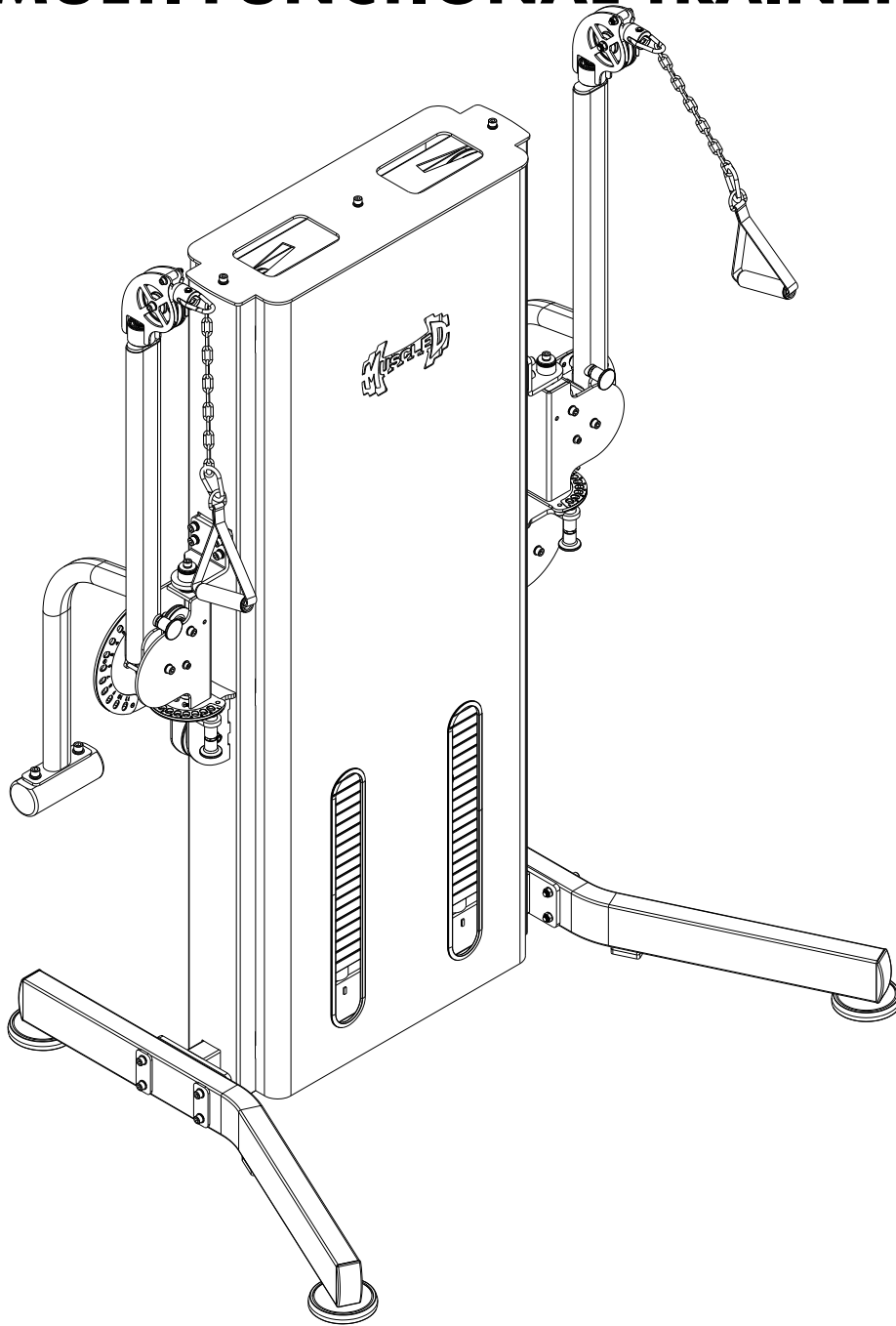

Installation Manual

www.muscledfit.com

Table of Contents

- 01/ Safety Instructions for Use
- 02/ Installation Steps Diagram and Checklist
- 03/ Product Description
- 04/ Product Specifications
- 05/ Maintenance Guide

01/ Safety Instructions for Use:

Thank you for choosing our product. Proper use of the equipment is essential for your safety and convenience. Please carefully read the following information before using the equipment:

1. Carefully read all user manuals before using this product, and strictly follow the instructions outlined in the manual. Keep the user manual for the entire lifespan of the product.
2. The product owner must ensure that all users understand the safety precautions.
3. When using this machine, keep the indoor air fresh and well-ventilated, and ensure there is ample space around the equipment.
4. Users are responsible for maintaining the equipment in good condition. After installation and before each use, check that all fasteners are tightened and there are no protruding parts. Regularly inspect components that may wear over time.
5. If the equipment is damaged, immediately contact the distributor or after-sales service department for replacement of worn or faulty parts. Do not use the equipment until it is fully repaired.
6. Wear appropriate workout clothing and shoes before using the machine. Avoid wearing skirts, jewelry, or accessories, and tie back long hair to prevent interference with your exercise.
7. Warm up before starting any exercise on this machine.
8. If you experience dizziness, pain, nausea, or any unusual symptoms, stop exercising immediately and consult a doctor.
9. Children should only use this equipment under adult supervision and for selected exercises.
10. **Warning!** Keep hands and feet away from moving parts.
11. **Warning!** Do not exceed the adjustment settings.
12. **Warning!** Keep children and pets away from the equipment while in use.
13. **Warning!** Ensure all adjustable components are securely set before use.
14. **Warning!** Use the machine as intended, as improper use or using functions beyond the machine's capabilities may harm your health.
15. It is recommended to use this equipment only in supervised areas.

02/ Installation Steps

1. Installation Step one

Finished Diagram

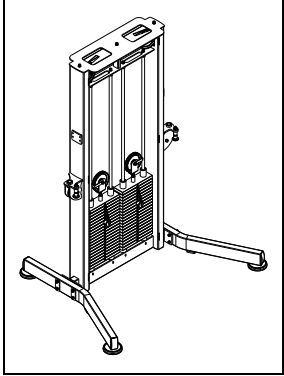

Checklist			
1	Top Cover		1
2	Gantry Frame		1
3	Support Tube 1		1
4	Support Tube 2		1
5	Cushion Plate	95*40*T3	4
6	M10X25 Hex Cylindrical Bolt		7
7	Spring Washer	Ø10	7
8	Flat Washer	Ø10	7
9	Guide Rod Fixing Sleeve	Ø30*33	4
10	Guide Rod Spacer Sleeve	Ø24*25	4
11	Guide Rod	4	2
12	Weight Stack		2
13	Shock Absorption Pad	Ø50*Ø22*45	4
14	M12X80 Hex Cylindrical Bolt		4
15	Flat Washer	Ø12	16
16	Hex Lock Nut	M12	8

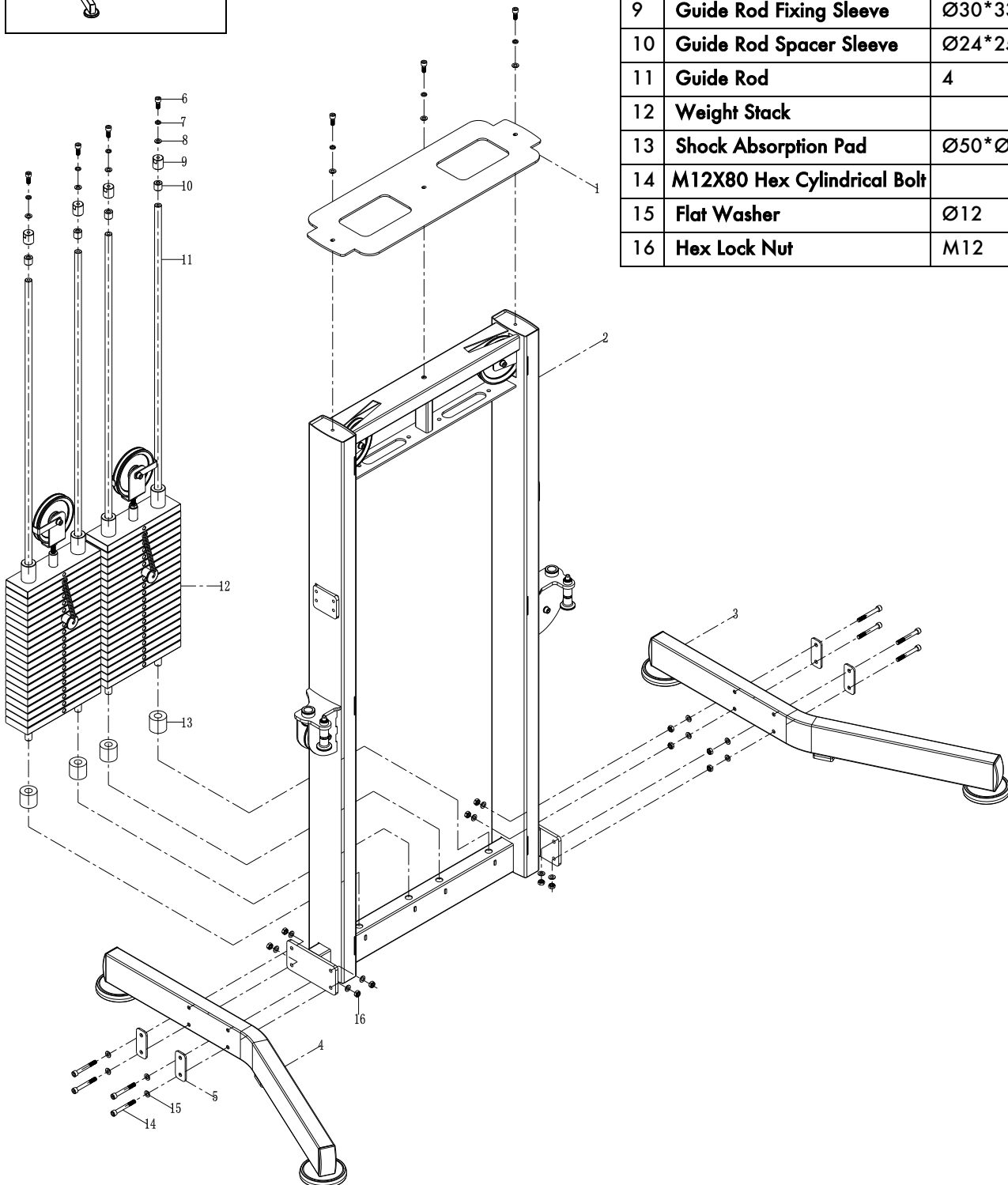

2. Installation Step Two

Finished Diagram

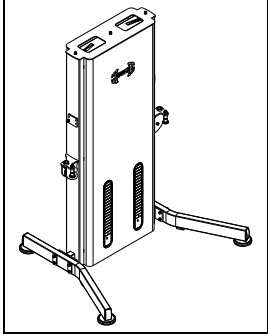

Checklist

17	Rear Gantry Guard Plate	1916.5*832.14*T2	1
18	Front Gantry Guard Plate	1916.5*832.14*T2	1

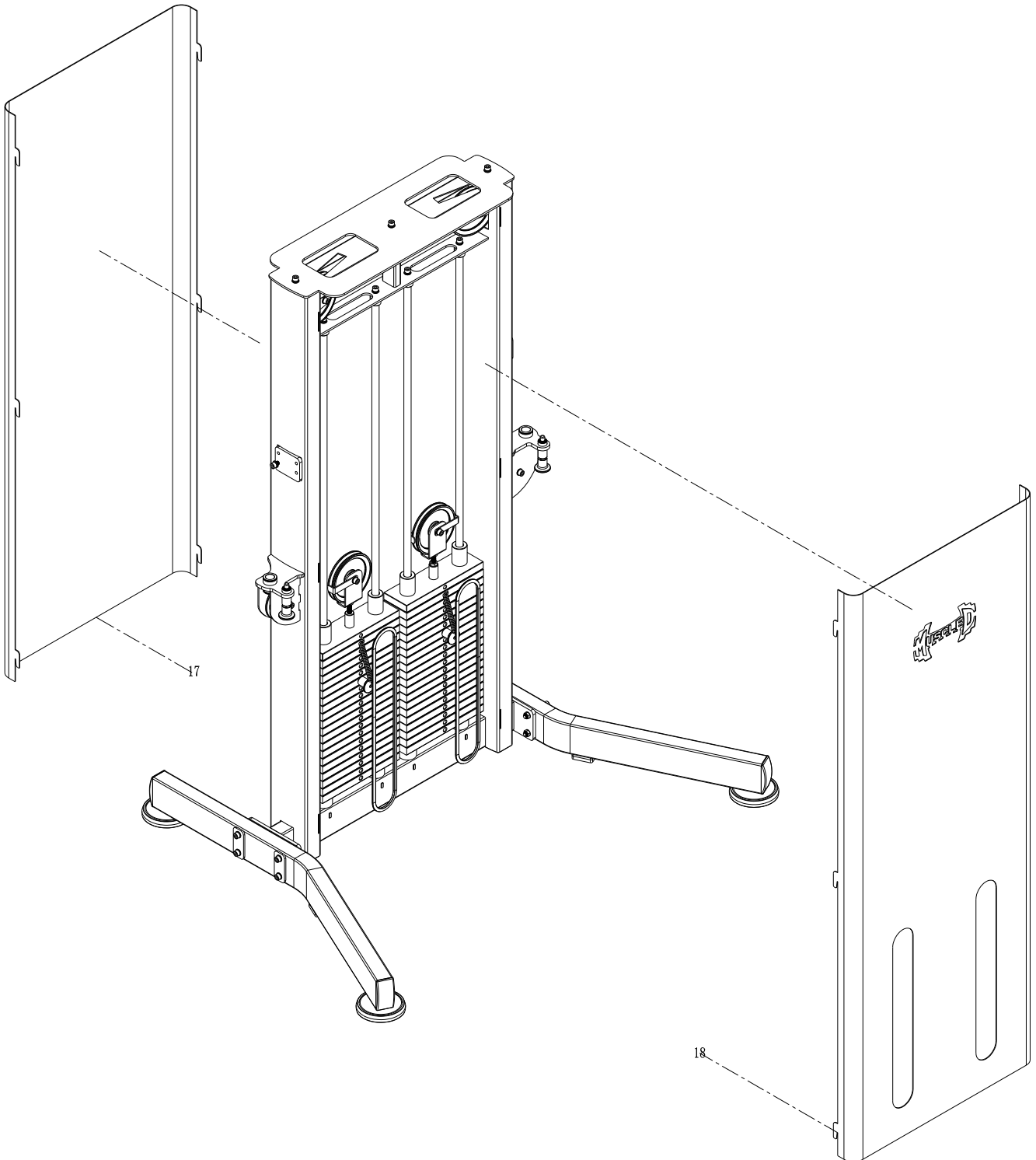

3. Installation Step Three

Finished Diagram

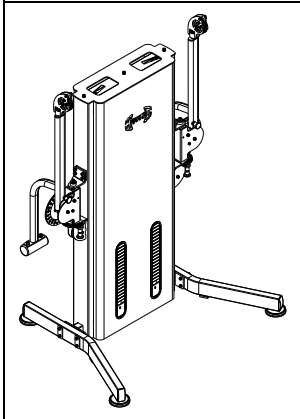

Checklist

19	Left Adjustment Tube		
20	M12X25 Hex Cylindrical Bolt		4
21	Spring Washer	Ø12	4
22	Flat Washer	Ø12	4
23	Weight Plate	Ø77*190	2
24	M10X95 Hex Cylindrical Bolt		2
25	Flat Washer	Ø10	12
26	Sleeve	Ø20*19.5	4
27	90 Pulley	Ø90* Ø10.5*25	2
28	Hex Lock Nut	M10	2
29	Right Rotating Component		1
30	M10X25 Hex Cylindrical Bolt		8
31	Spring Washer	Ø10	10
32	Large Flat Washer	Ø10(Ø30*T2.5)	2
33	M10X20 Hex Cylindrical Bolt		2
34	Fixed Connector		1
35	Type A Elastic Shaft Circlip	Ø25-GB/T894.1-1986	4
36	Left Rotating Component		1
37	Fixed Connector		1
38	Right Adjustment Tube		1

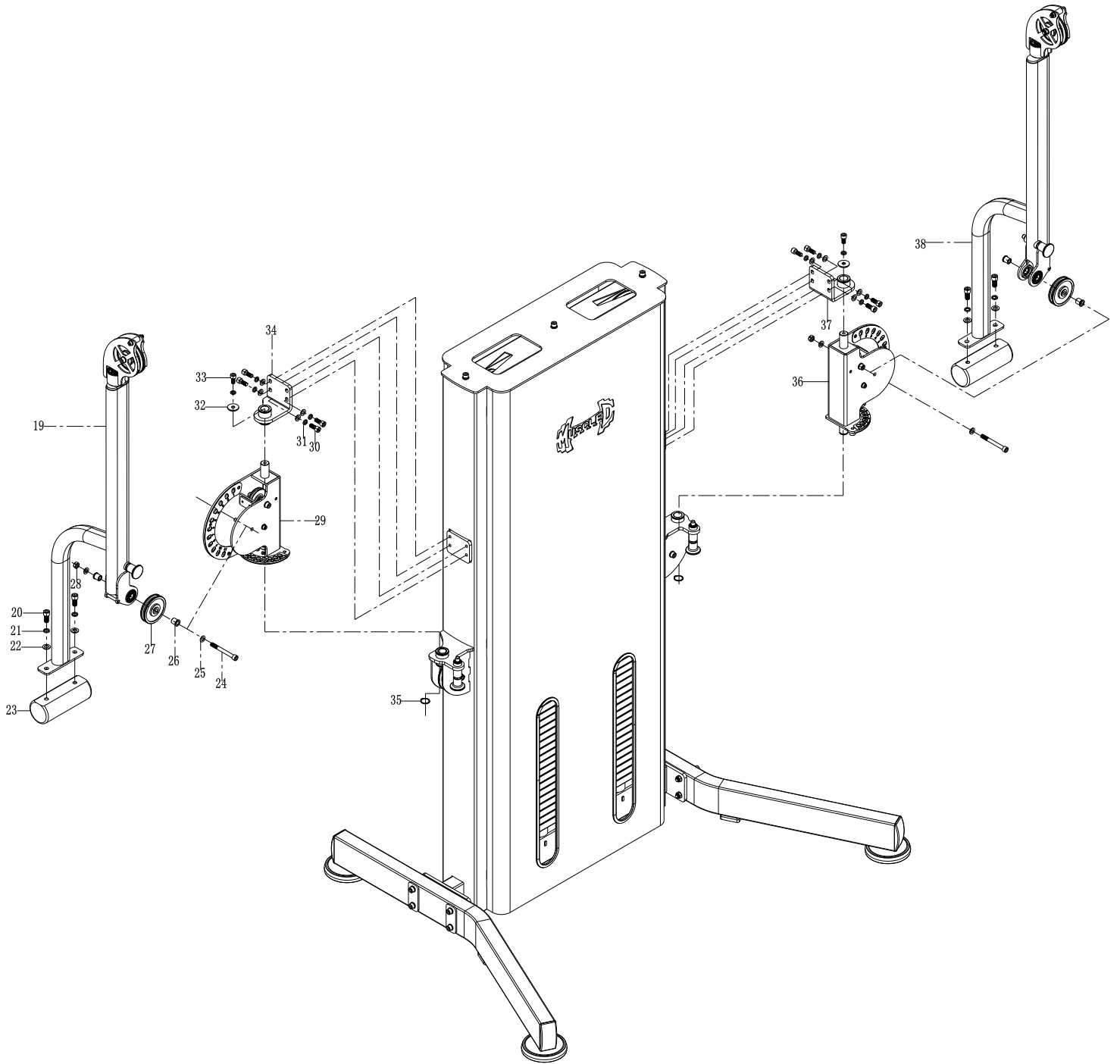

4. Installation Step Four Pulley Installation Diagram:

Checklist			
39	Single Pull Handle		2
40	Pulley Hook	50*82*Ø8	4
41	Chain	39*21*Ø6*12 节(L375)	2
42	Wire Rope Locking Clamp		2
43	Steel Wire Rope		2
44	90 Pulley		4
45	Ø70 Pulley		2
46	Ø115 Pulley		4
47	Ø150 Pulley		4
48	M10X20 Hex Cylindrical Bolt		2
49	Flat Washer	Ø10	4
50	Hex Lock Nut	M10	2

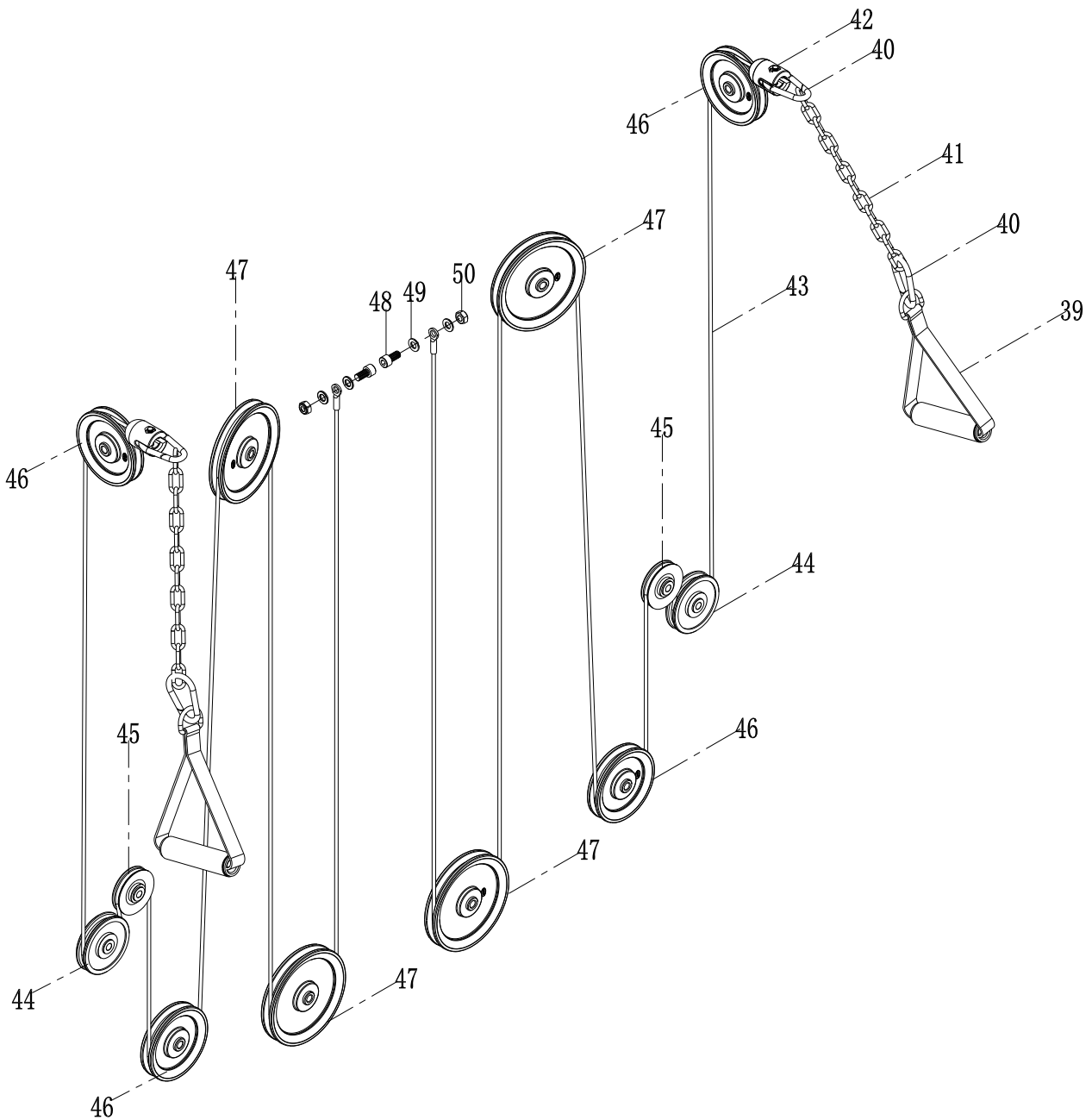

03/ Product Description

This machine is an indoor fitness device designed for aerobic cardiovascular exercise, primarily focused on improving heart and lung function, with muscle training as a secondary goal. It targets muscles such as the chest and other areas, helping to strengthen the body and improve overall fitness. The machine features a functional diagram that clearly demonstrates how to use the equipment and effectively train muscles, making it easy to understand. With its weight stack assembly, users can easily adjust the intensity and resistance to meet their training needs. Designed to follow human motion trajectories, this machine ensures safety and durability.

- The machine is constructed using large-diameter steel tubing and treated with electrostatic powder coating, ensuring safety, reliability, and durability.

04/ Product Specifications

Name	Megatron Multi-Functional Trainer	SKU	MT-MFT
Dimensions	97" L x 141" W x 98" H		
Weight	871 lb		

05/ Maintenance Guide

1. The bolts of all machine parts should be regularly checked and kept tightened. Moving parts should operate smoothly without any unusual noise.
2. The machine should be kept clean, but strong cleaning solvents should not be used for wiping.
3. Any worn or damaged load-bearing components should be replaced immediately, and the machine should not be used until fully repaired.