

MEGATRON STANDARD & DELUXE (after page 15)

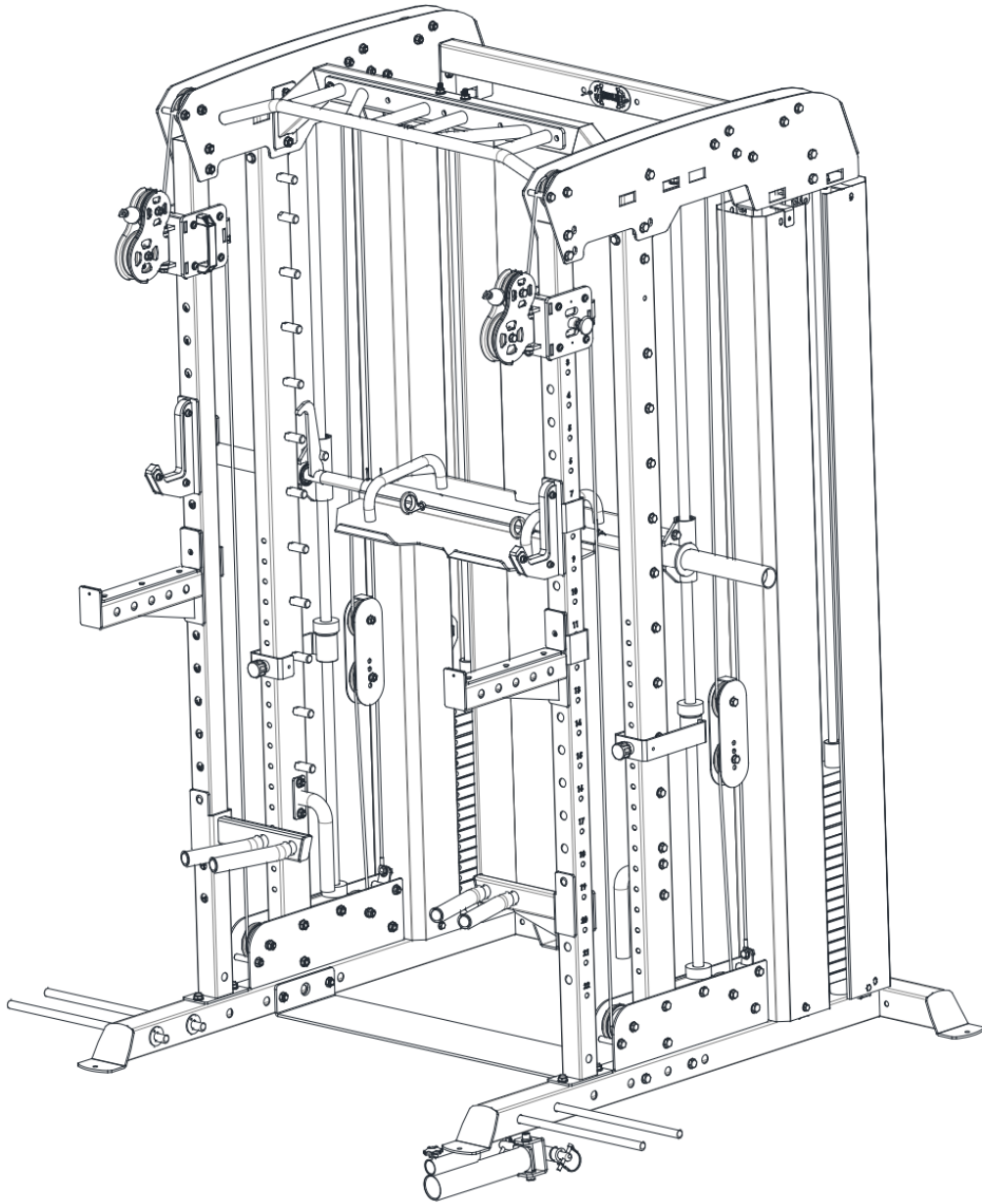

SM-13 ASSEMBLY INSTRUCTIONS MEGATRON STANDARD MACHINE

CONTENTS

01/IMPORTANT NOTICE

02/ ASSEMBLY PROCEDURE AND BILL OF MATERIALS

03/PRODUCT DESCRIPTION

04/PRODUCT PARAMETER

05/MAINTENANCE GUIDELINE

06/TROUBLESHOOTING

07/WARRANTY INSTRUCTION

01/IMPORTANT NOTICE

Thank you for choosing our machine, proper use of the machine is important to keep you convenient and away from

danger. Please read the instruction before operating the machine:

1. Please read all user manuals before operating the machine and operate the machine according to the instructions.

Please keep the user manual until the machine is no longer in use!

2. Please read and understand all cautions!

3. Keep enough space for users when operating the machine.

4. Keep the machine in good condition. Ensure all fixed parts are tightened and no parts are left over. Inspect the parts subject to wear regularly.

5. Please contact the dealer or after-sales department to change worn out or defective parts. DO NOT operate the machine when it is out of use.

6. Please wear proper sports dress and gym shoes before operating it. DO NOT wear a skirt or jewelry while using. Tie up user's hair to avoid any possible dangers.

7. Do warm-up exercises before operating the machine.

8. Stop workout and ask your doctor when the user experiences abnormal symptoms occur such as headache, pain, etc.

9. Children must exercise under the supervision of adults.

10. WARNING: Keep hands and feet away from moving parts.

11. WARNING: DO NOT beyond adjustable setting range.

12. WARNING: Keep children or pets away from the machine when operating it.

13. WARNING: Keep all control apparatus in proper position.

14. WARNING: Please operate the machine in proper way as improper operating may not achieve the desired workout effect of the machine...and may lead to injury!

15. Operating the machine in a controlled area is recommended.

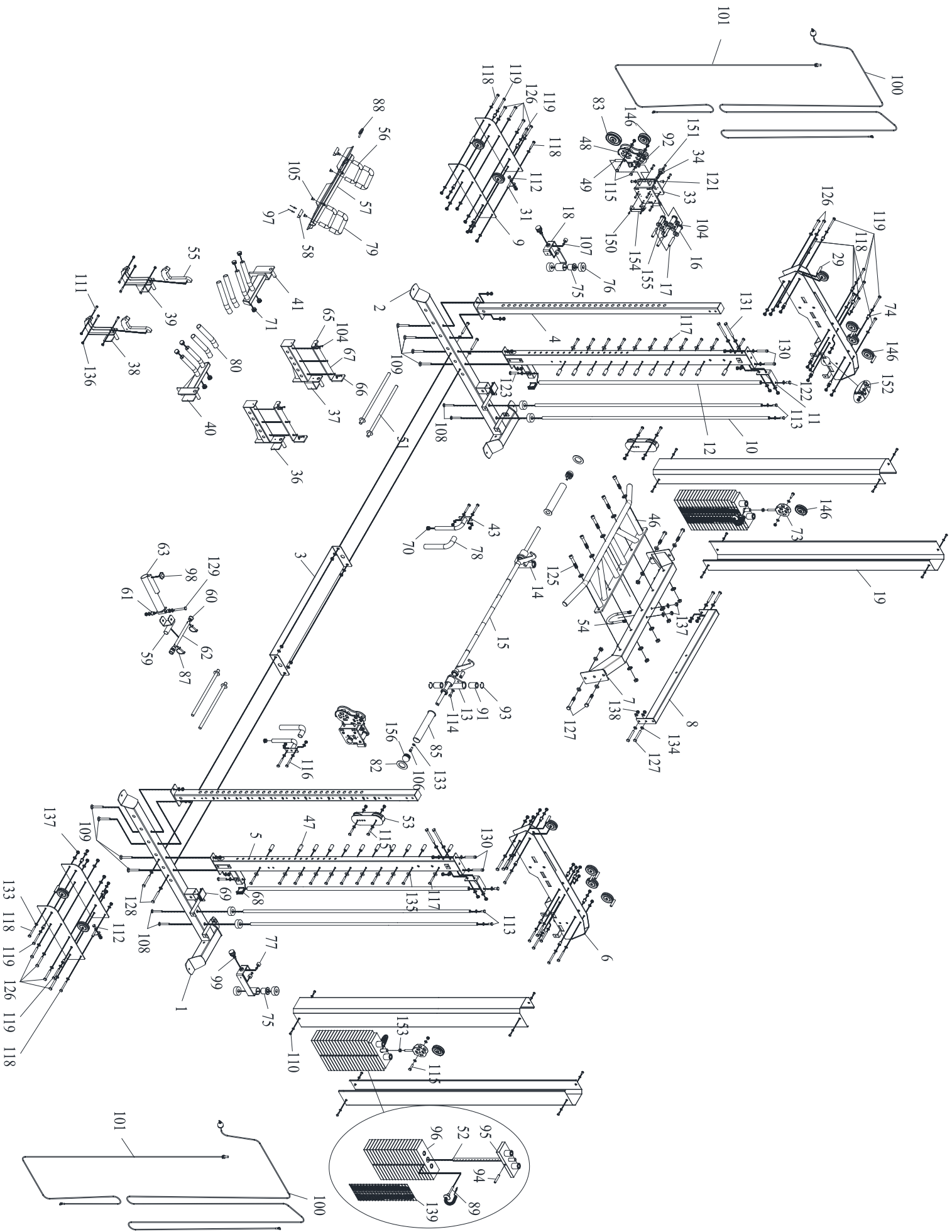

02/ASSEMBLY PROCEDURE

1) Step 1

Bill of materials			
No.	Name	Specification	Qty
1	Right bottom tube	Weldment	1
2	Left bottom tube	Weldment	1
4	upright	Weldment	2
5	Upright	Weldment	2
10	Guide rod	Weldment	4
43	Handle	Weldment	2
47	Small rod	φ20*50	24
76	Crash pad	φ50*φ22*45	4
108	Carriage bolt	M10*85	4
109	Carriage bolt	M12*95	8
116	Hexagon socket cylinder head bolt	M10*70	4
117	Hexagon socket cylinder head bolt	M10*75	24
133	Flat washer	Φ10	8
134	Flat washer	Φ12	8
135	Large flat washer	Φ10	24
137	Hexagon lock nut	M10	4
138	Hexagon lock nut	M12	8

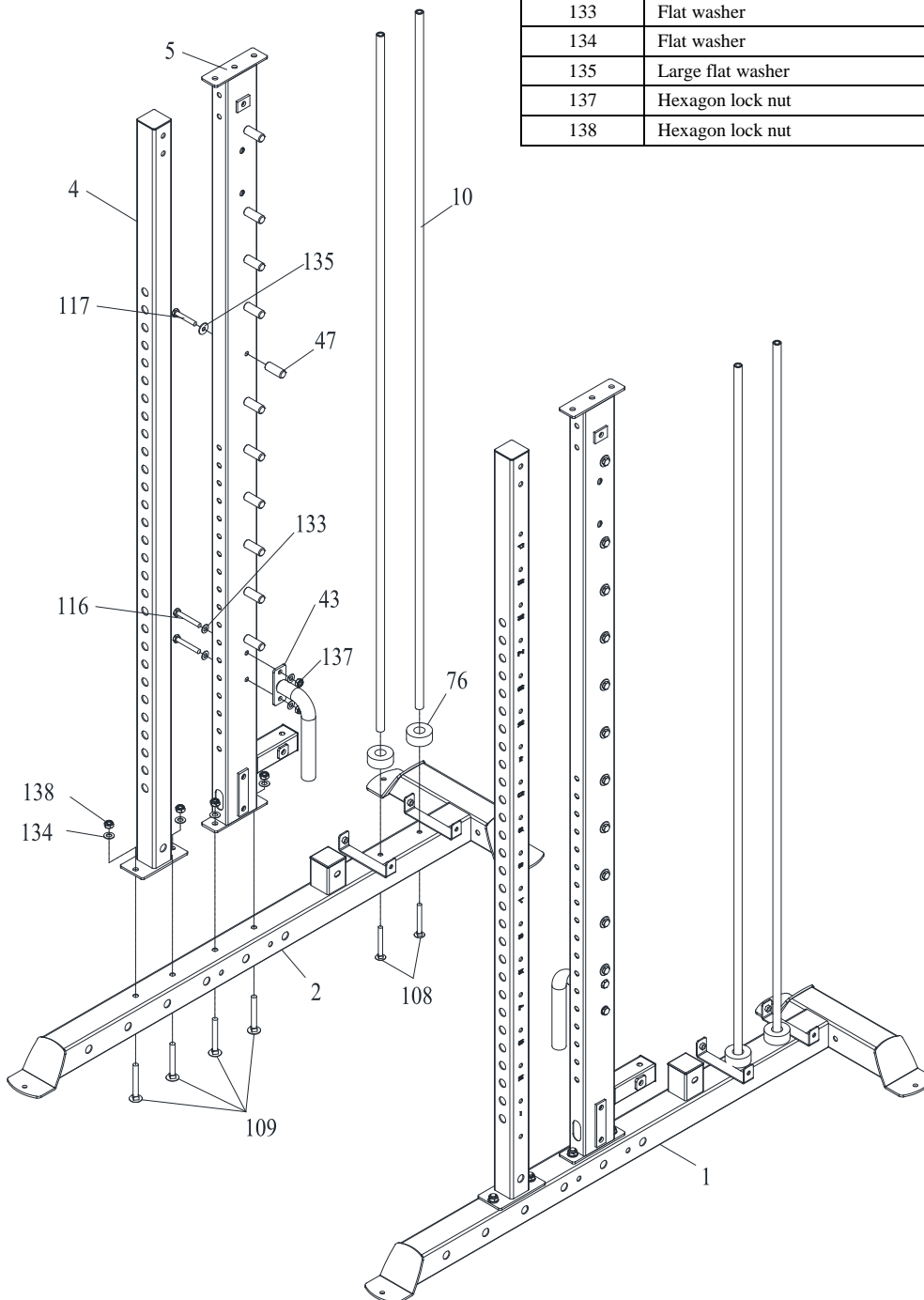

2) Step 2

Bill of materials			
No.	Name	Specification	Qty
3	Checkered plate	T6*200*1227	1
128	Hexagon socket cylinder head bolt	M12*95	4
134	Flat washer	Φ12	8
138	Hexagon lock nut	M12	4

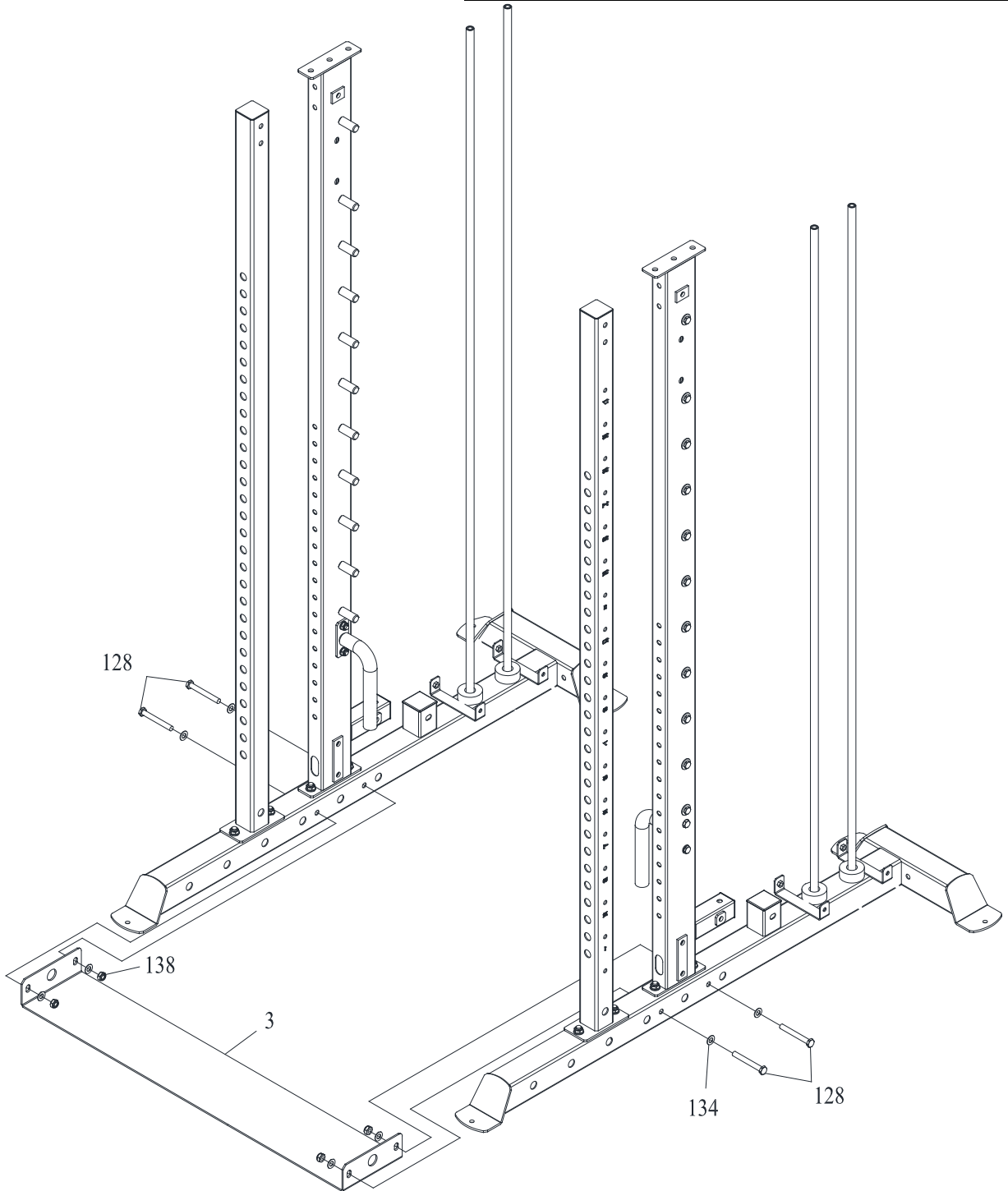

3) Step 3

Bill of materials			
No.	Name	Specification	Qty
33	Sliding block	Weldment	2
52	Weight stack selector B		2
83	Aluminum pulley	Φ114	2
89	Selector pin		3
94	Round-shaped shaft		3
95	Top plate		3
96	Weight stack		62
115	Hexagon socket cylinder head bolt	M10*50	2
133	Flat washer	Φ10	4
137	Hexagon lock nut	M10	2
139	Weight stack label		3
146	Aluminum pulley	Φ90	2

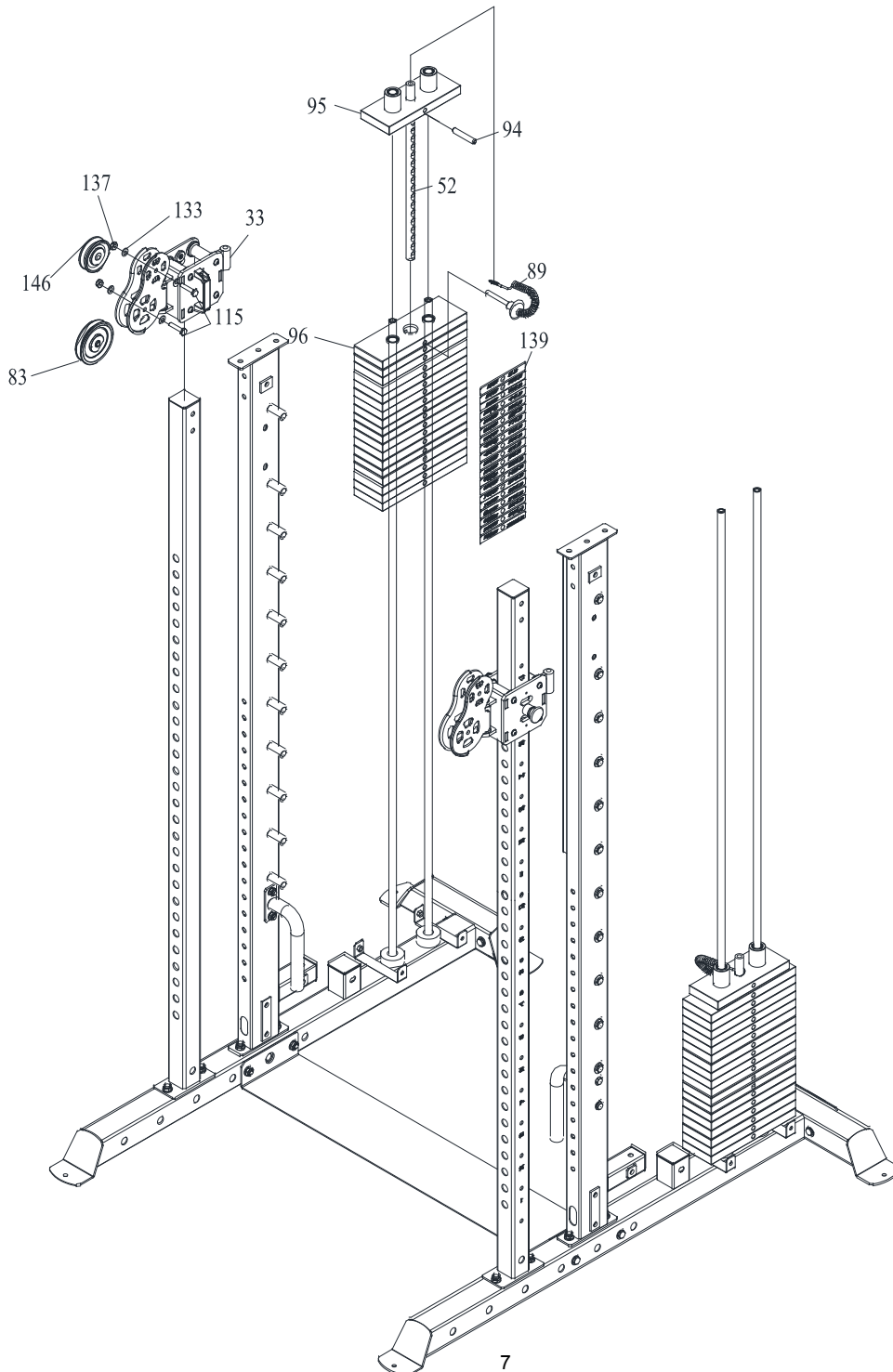

4) Step 4

Bill of materials			
No.	Name	Specification	Qty
11	Guide rod bracket	Weldment	2
12	LM shaft	φ25*1929	2
18	Buffer bracket	Weldment	2
76	Rubber Bumper	φ50*φ22*45	4
82	Rubber buffer ring	Φ80*Φ50*T5	2
99	Quick pull pin	Ø38*M16*1.5	2
122	Hexagon socket cylinder head bolt	M12*25	2
123	Hexagon socket cylinder head bolt	M12*70	2
131	Hexagon socket cylinder head bolt	M12*120	4
134	Flat washer	Φ12	12
138	Hexagon lock nut	M12	4

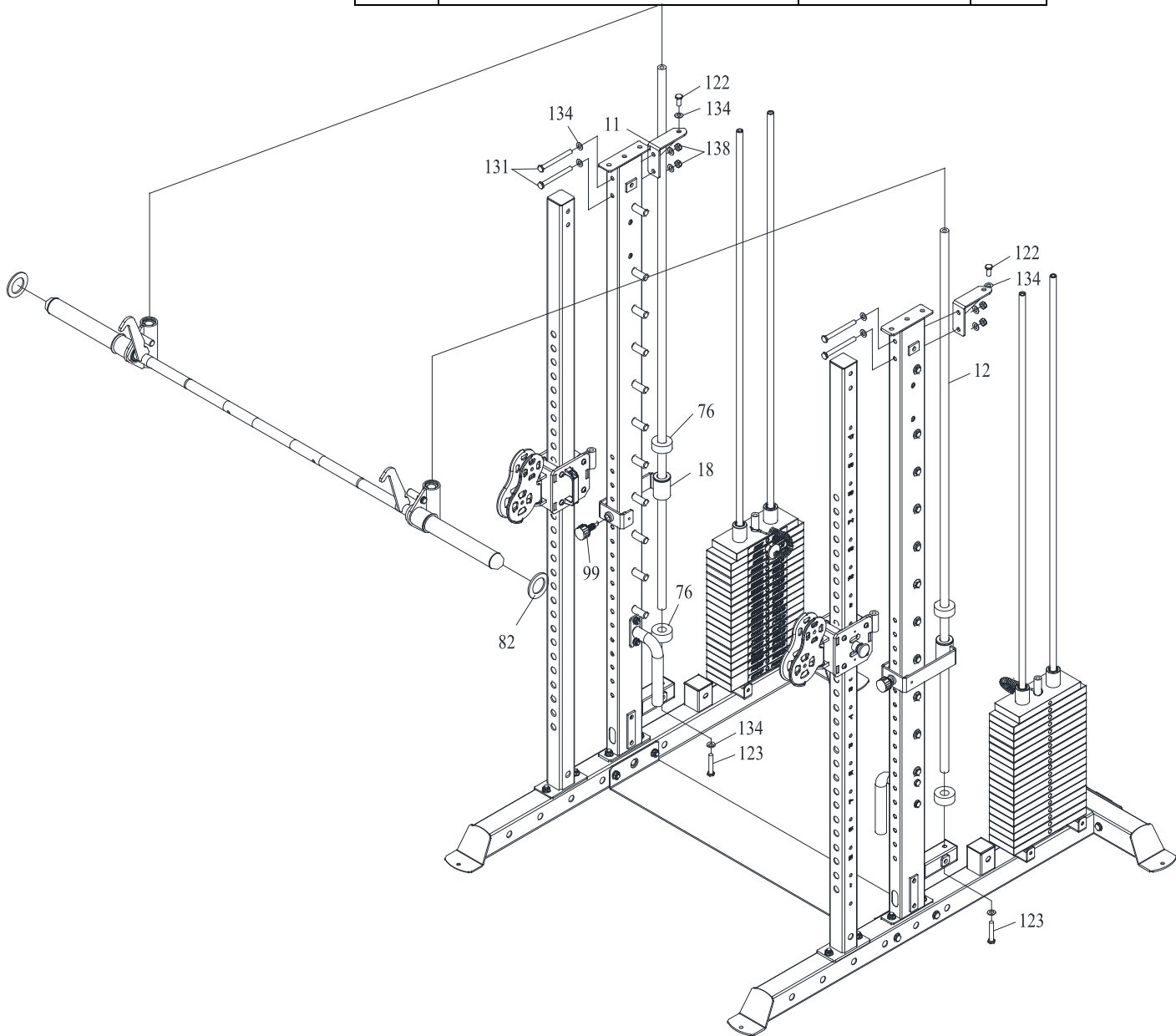

5) Step 5

Bill of materials			
No.	Name	Specification	Qty
6	Short frame	Weldment	2
29	Cable bumping post 1	Round tube $\phi 14 * T 1.5 * 60$	8
74	Nylon bush	$\Phi 16 * 24$	16
113	Hexagon bolt	M10*25	4
118	Hexagon socket cylinder head bolt	M10*85	8
119	Hexagon socket cylinder head bolt	M10*90	8
126	Hexagon socket cylinder head bolt	M12*85	4
130	Hexagon socket cylinder head bolt	M12*80	4
133	Flat washer	$\Phi 10$	36
134	Flat washer	$\Phi 12$	16
137	Hexagon lock nut	M10	16
138	Hexagon lock nut	M12	8
146	Aluminum pulley	$\Phi 90$	8

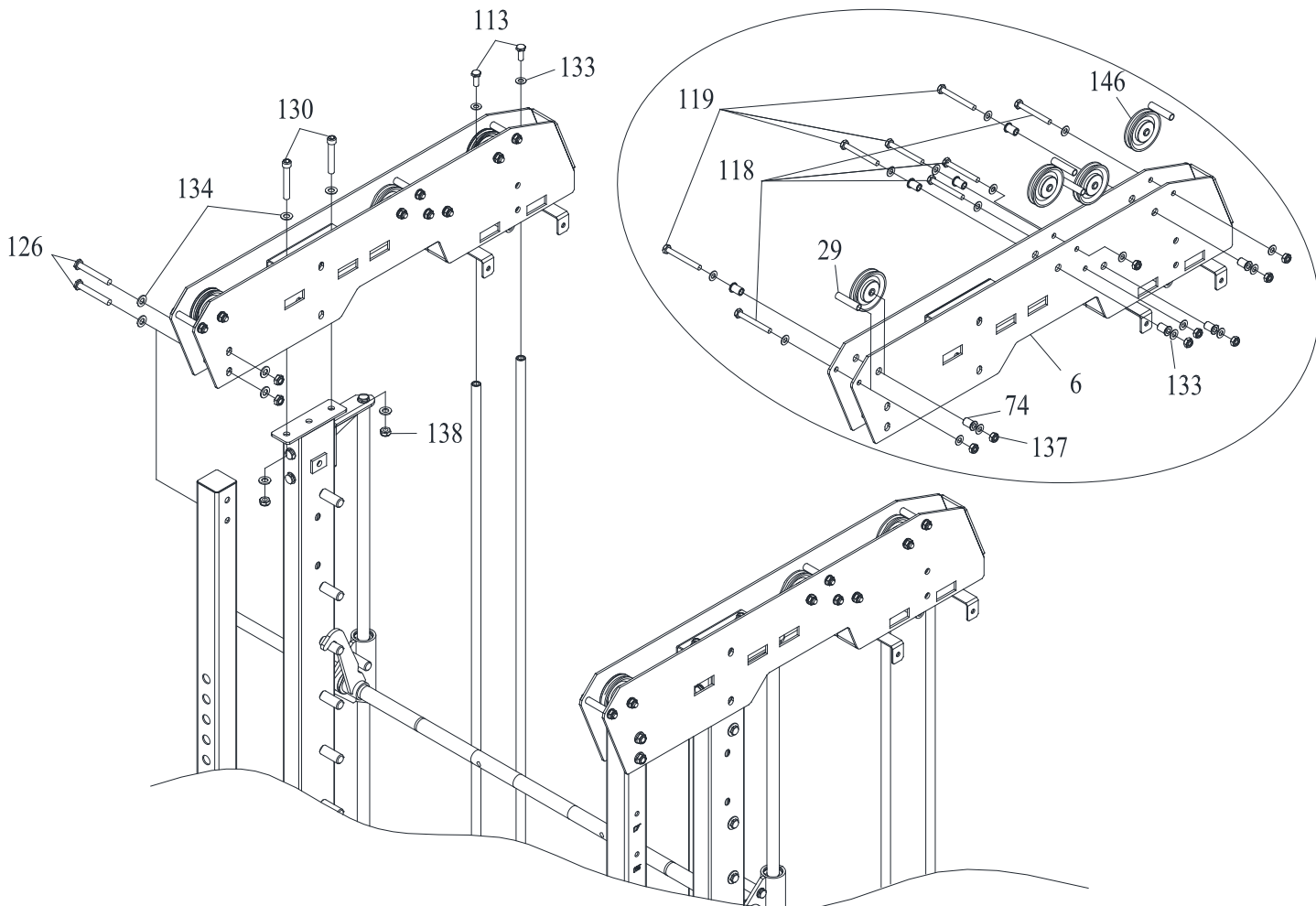

6) Step 6

Bill of materials			
No.	Name	Specification	Qty
7	Front upper connecting assembly	Weldment	1
8	Rear upper connecting assembly	Weldment	1
46	Chin-up frame	Weldment	1
54	Lifting hook	Round steel ϕ 12*314	1
125	Hexagon socket cylinder head bolt	M12*80	9
127	Hexagon socket cylinder head bolt	M12*90	8
133	Flat washer	Φ 10	6
134	Flat washer	Φ 12	34
137	Hexagon lock nut	M10	6
138	Hexagon lock nut	M12	17

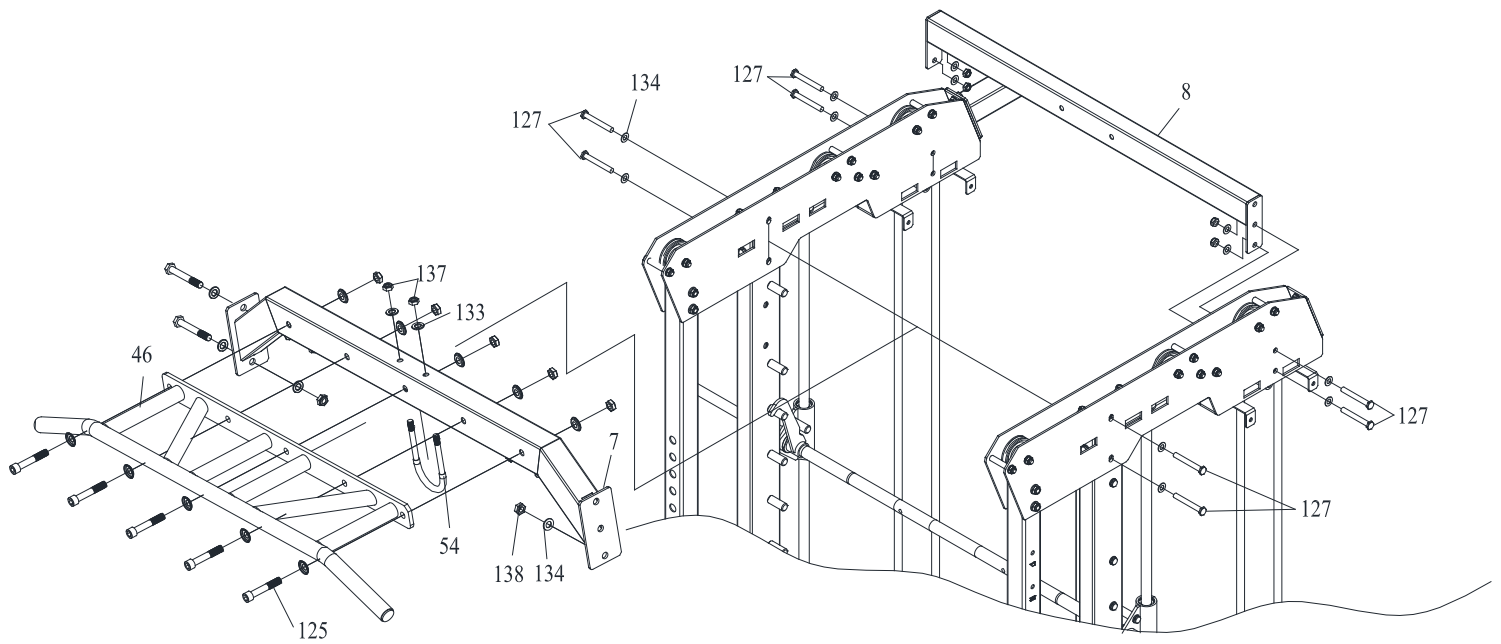

7) Step 7

Bill of materials			
No.	Name	Specification	Qty
9	Bottom pulley baffle	Steel plate T5*532.5*150	4
29	Cable bumping post 1	Round tube $\phi 14 * T1.5 * 60$	2
31	Bracket	Weldment	2
74	Nylon bush	$\Phi 16 * 24$	8
118	Hexagon socket cylinder head bolt	M10*85	4
119	Hexagon socket cylinder head bolt	M10*90	4
126	Hexagon socket cylinder head bolt	M12*85	8
133	Flat washer	$\Phi 10$	16
134	Flat washer	$\Phi 12$	16
137	Hexagon lock nut	M10	8
138	Hexagon lock nut	M12	8
146	Aluminum pulley	$\Phi 90$	4

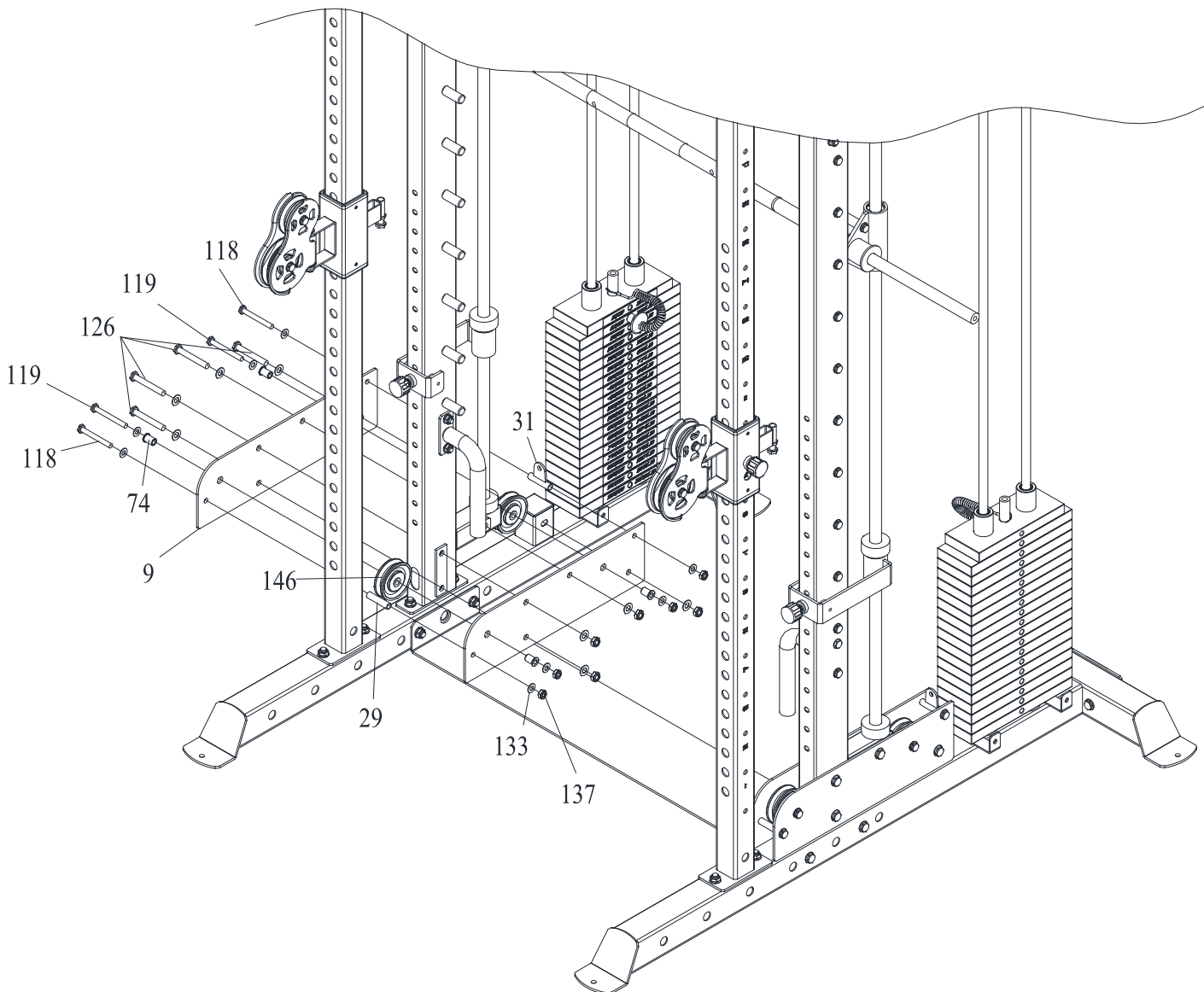

8) Step 8

Bill of materials			
No.	Name	Specification	Qty
53	Pulley frame	Weldment	3
73	Pulley seat	Weldment	2
100	SWC08 Cable 3	Φ5*6955	2
101	SWC08 Cable 4	Φ5*3220	2
112	Hexagon socket cylinder head bolt	M10*25	2
115	Hexagon socket cylinder head bolt	M10*50	8
133	Flat washer	Φ10	24
137	Hexagon lock nut	M10	12
146	Aluminum pulley	Φ90	8
152	Hexagon socket cylinder head bolt	M10*30	2
153	Hexagon lock nut	M12	2

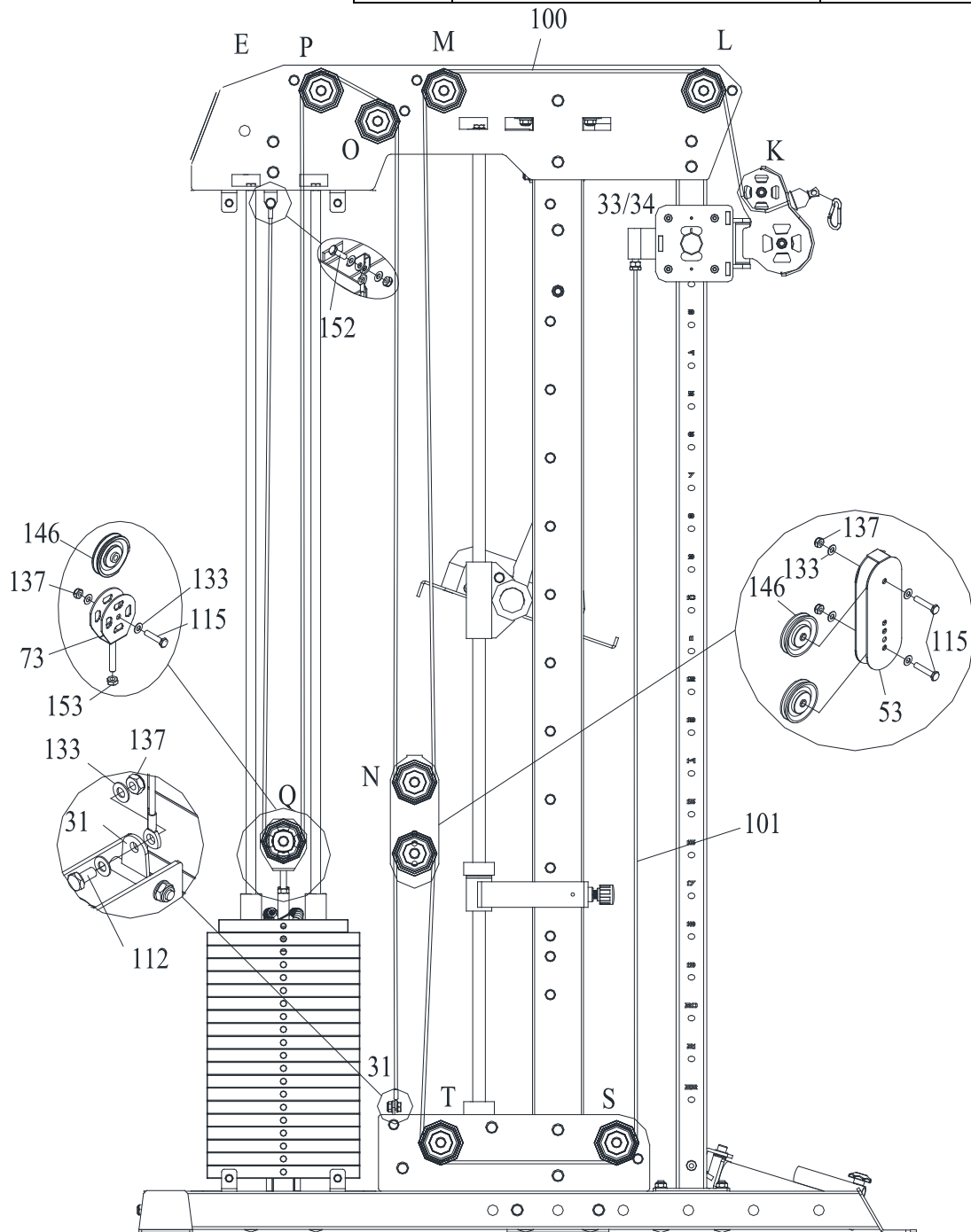

9) Step 9

Bill of materials			
No.	Name	Specification	Qty
19	Shroud	T1*1963*484.2	6
110	Hexagon socket cylinder head bolt	M8*16	24
132	Flat washer	Φ8	24

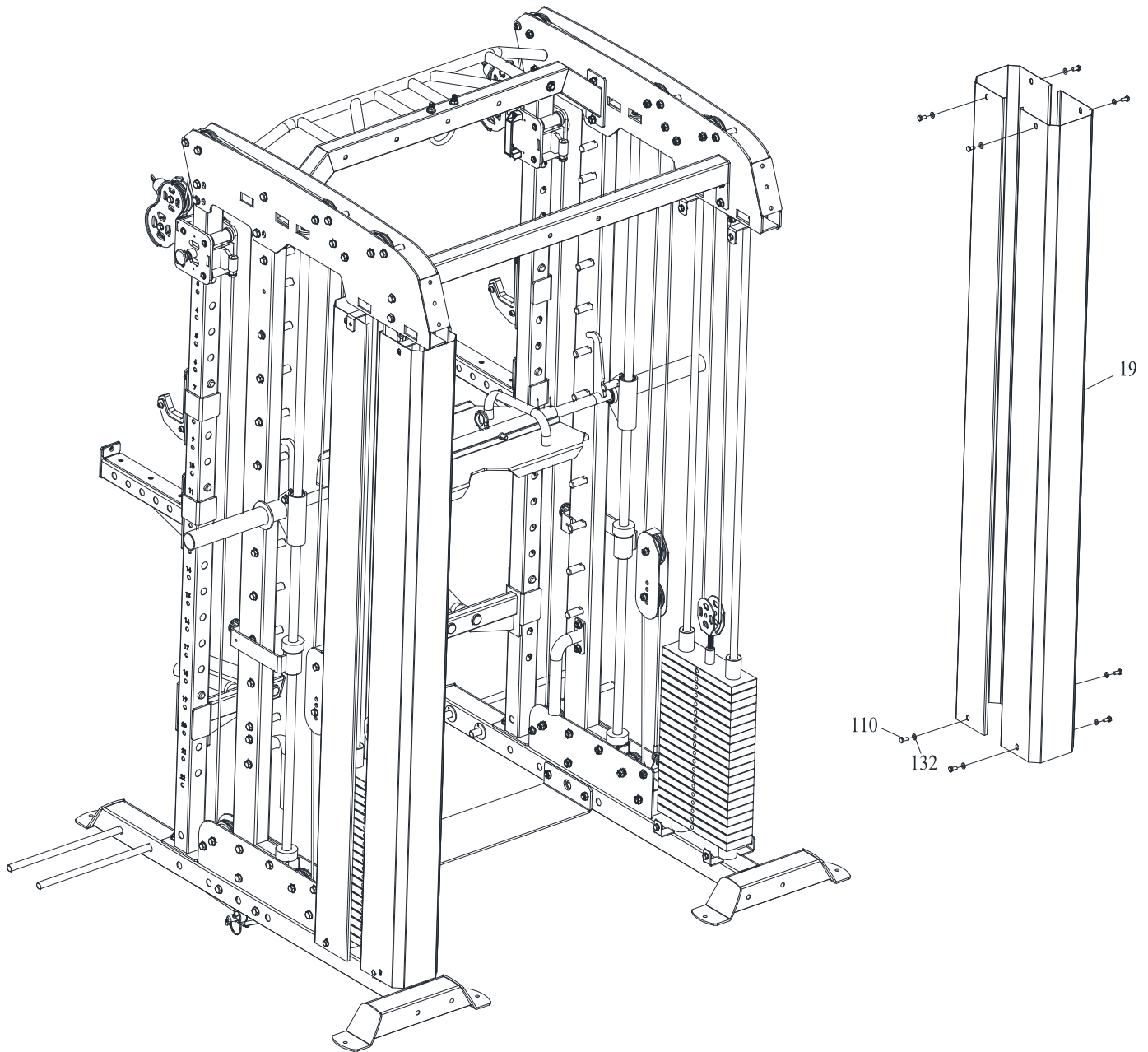

10) Step 10

Bill of materials			
No.	Name	Specification	Qty
57	Footboard assembly	Weldment	1
88	L-shaped latch	$\Phi 10 \times 70$	2

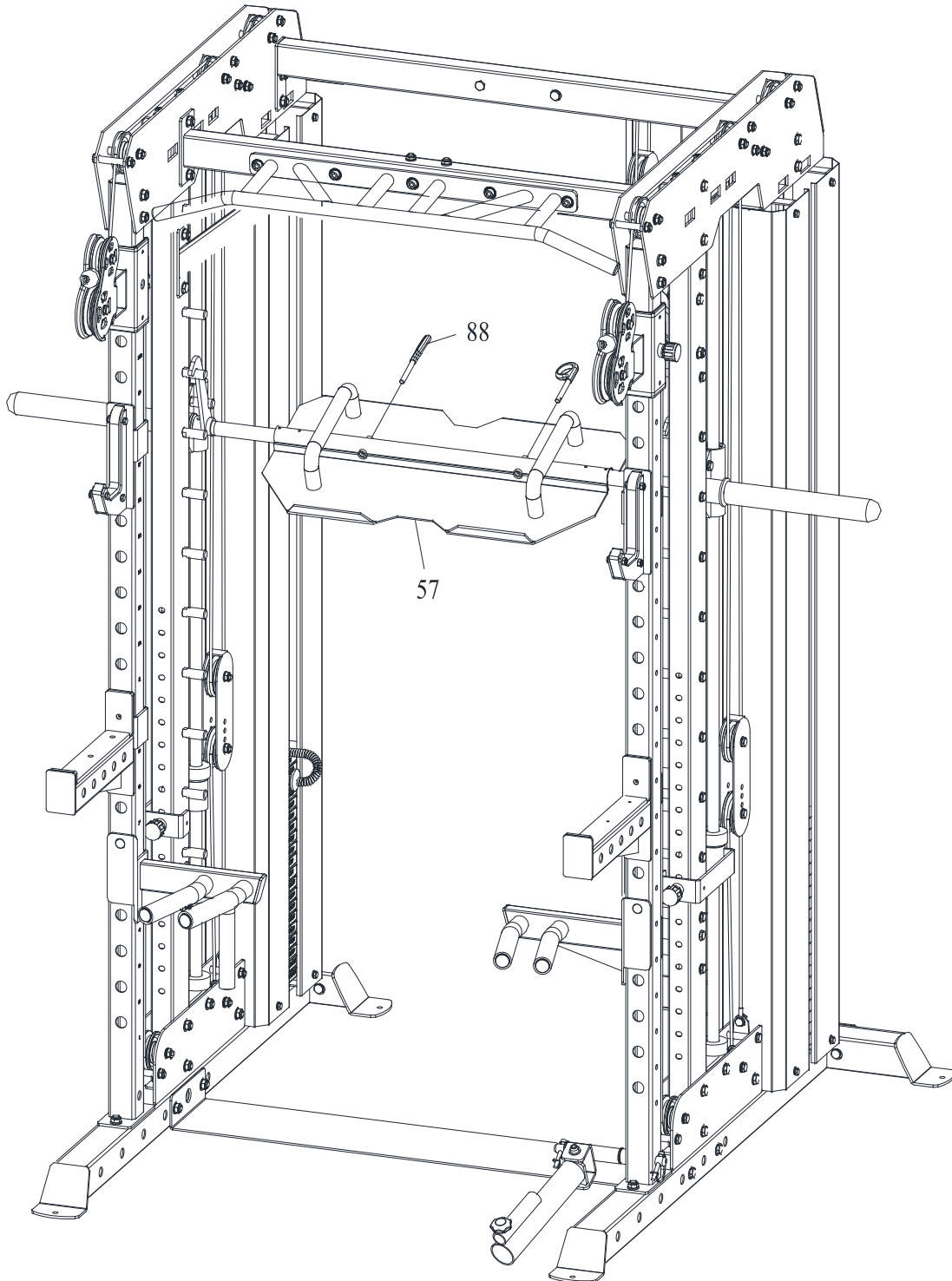

03/ PRODUCT DESCRIPTION

The machine is for indoor fitness equipment use. It is suitable for anaerobic exercise, mainly used to train the total body muscles while improving cardio-pulmonary functions. Working out with the machine will enhance overall muscularity.

Users can adjust the resistance by weight stack easily.

The design and manufacture of the machine meets the human anatomy while the safety and durability are very important for the users.

The design and manufacture of the machine meets the human motion curve, and meets the standard of specifications of GB17498.1-2008 and GB17498.2-2008. The durability is guaranteed.

Large size steel tube and electrostatic spraying guarantee the safety and durability.

04/ PRODUCT PARAMETER

Name: Megatron Deluxe Model SM-12

Floor space 1900mm x 1900mm x 2350mm, 76 in x 76 in x 93 in.

Weight stacks(2), 90 Kg each/(200 lbs each)

05/ MAINTENANCE GUIDELINE

1. All the bolts and screws should be inspected regularly and kept tightened, and rotating parts should be flexible without abnormal noise.
2. The machine should be kept clean. Please DO NOT clean the machine with strong cleaning solvent.
3. Any worn or damaged stressed parts should be repaired or changed immediately.

06/ TROUBLESHOOTING

07/ WARRANTY INSTRUCTION

1. Warranty scope

The machine is not cover for damages by any misuse while under proper maintenance. The warranty card is valid only for the original buyer.

2. The warranty period is one year after purchase of the machine.

3. The below-listed damages are out of warranty:

- 1). damages caused by abuse, carelessness, accident or unauthorized modify.
- 2). damages caused by improper adjustment of weight stack pins.
- 3). damages caused by improper maintenance.
- 4). damages caused by other improper operations of the machine.

MEGATRON DELUXE

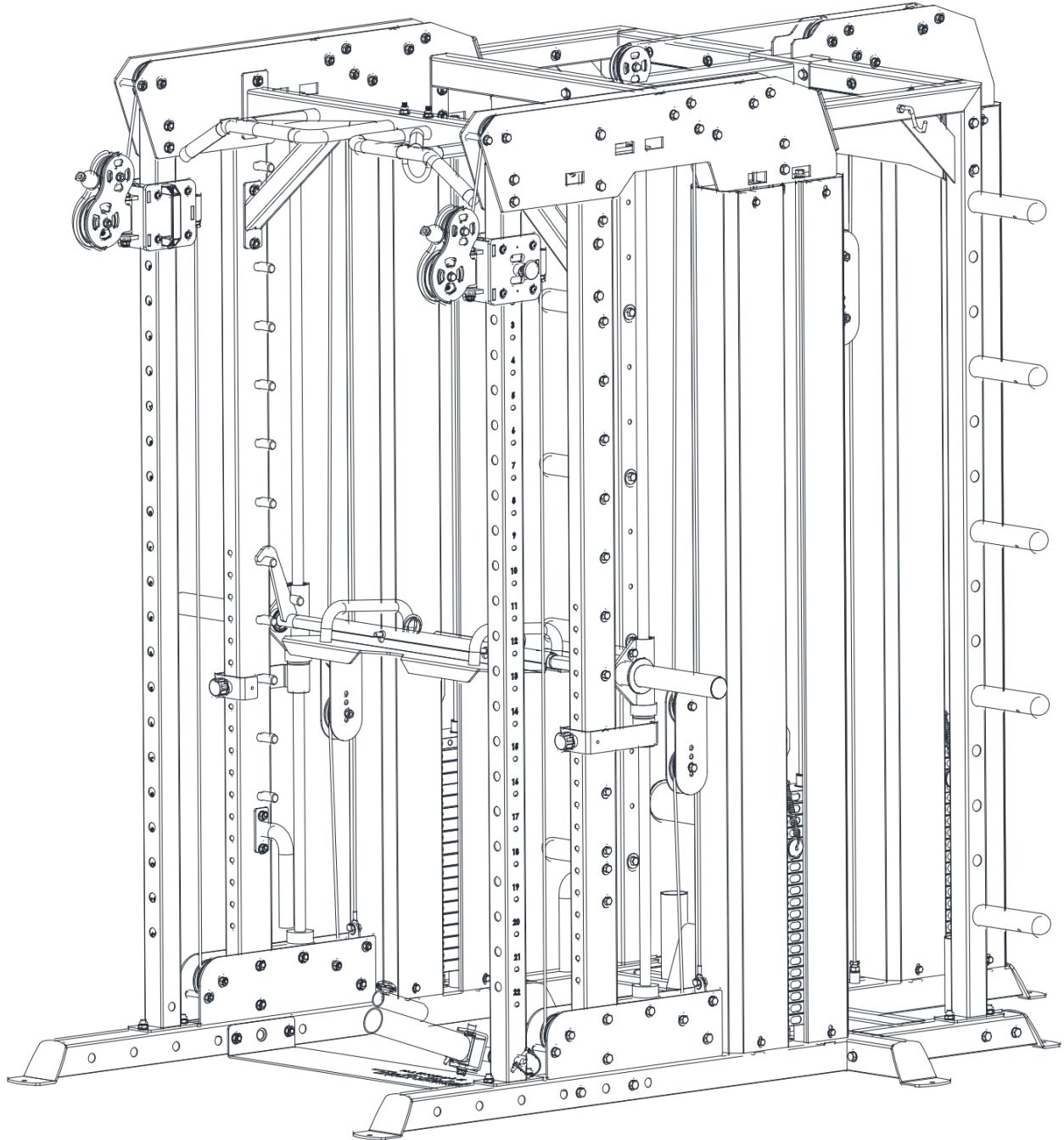

SM-12 ASSEMBLY INSTRUCTIONS

CONTENTS

01/IMPORTANT NOTICE

02/ ASSEMBLY PROCEDURE AND BILL OF MATERIALS

03/PRODUCT DESCRIPTION

04/PRODUCT PARAMETER

05/MAINTENANCE GUIDELINE

06/TROUBLESHOOTING

07/WARRANTY INSTRUCTION

01/IMPORTANT NOTICE

Thank you for choosing our machine, proper use of the machine is important to keep you convenient and away from

danger. Please read the instruction before operating the machine:

1. Please read all user manuals before operating the machine and operate the machine according to the instructions.

Please keep the user manual until the machine is no longer in use!

2. Please read and understand all cautions!

3. Keep enough space for users when operating the machine.

4. Keep the machine in good condition. Ensure all fixed parts are tightened and no parts are left over. Inspect the parts subject to wear regularly.

5. Please contact the dealer or after-sales department to change worn out or defective parts. DO NOT operate the machine when it is out of use.

6. Please wear proper sports dress and gym shoes before operating it. DO NOT wear a skirt or jewelry while using. Tie up user's hair to avoid any possible dangers.

7. Do warm-up exercises before operating the machine.

8. Stop workout and ask your doctor when the user experiences abnormal symptoms occur such as headache, pain, etc.

9. Children must exercise under the supervision of adults.

10. WARNING: Keep hands and feet away from moving parts.

11. WARNING: DO NOT beyond adjustable setting range.

12. WARNING: Keep children or pets away from the machine when operating it.

13. WARNING: Keep all control apparatus in proper position.

14. WARNING: Please operate the machine in proper way as improper operating may not achieve the desired workout effect of the machine...and may lead to injury!

15. Operating the machine in a controlled area is recommended.

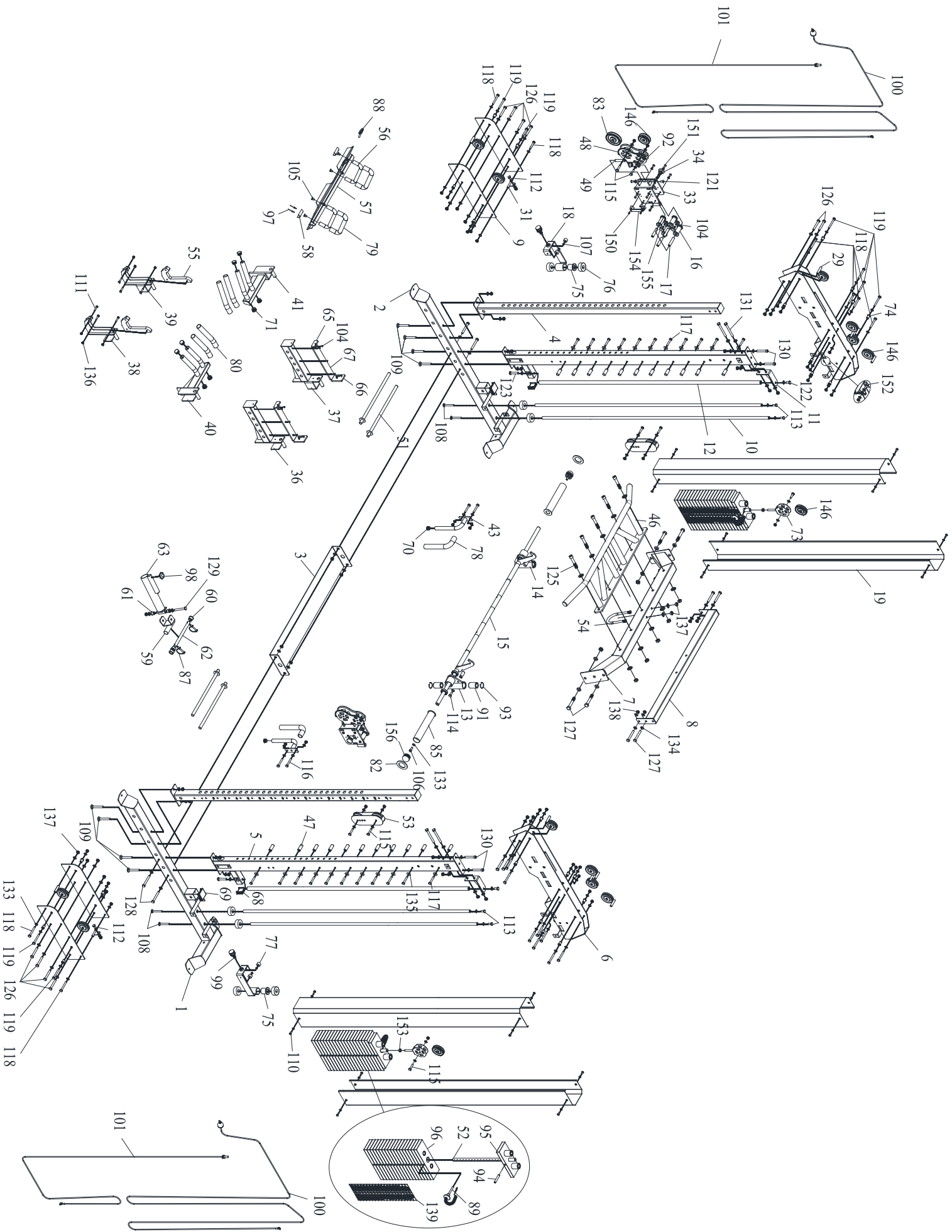

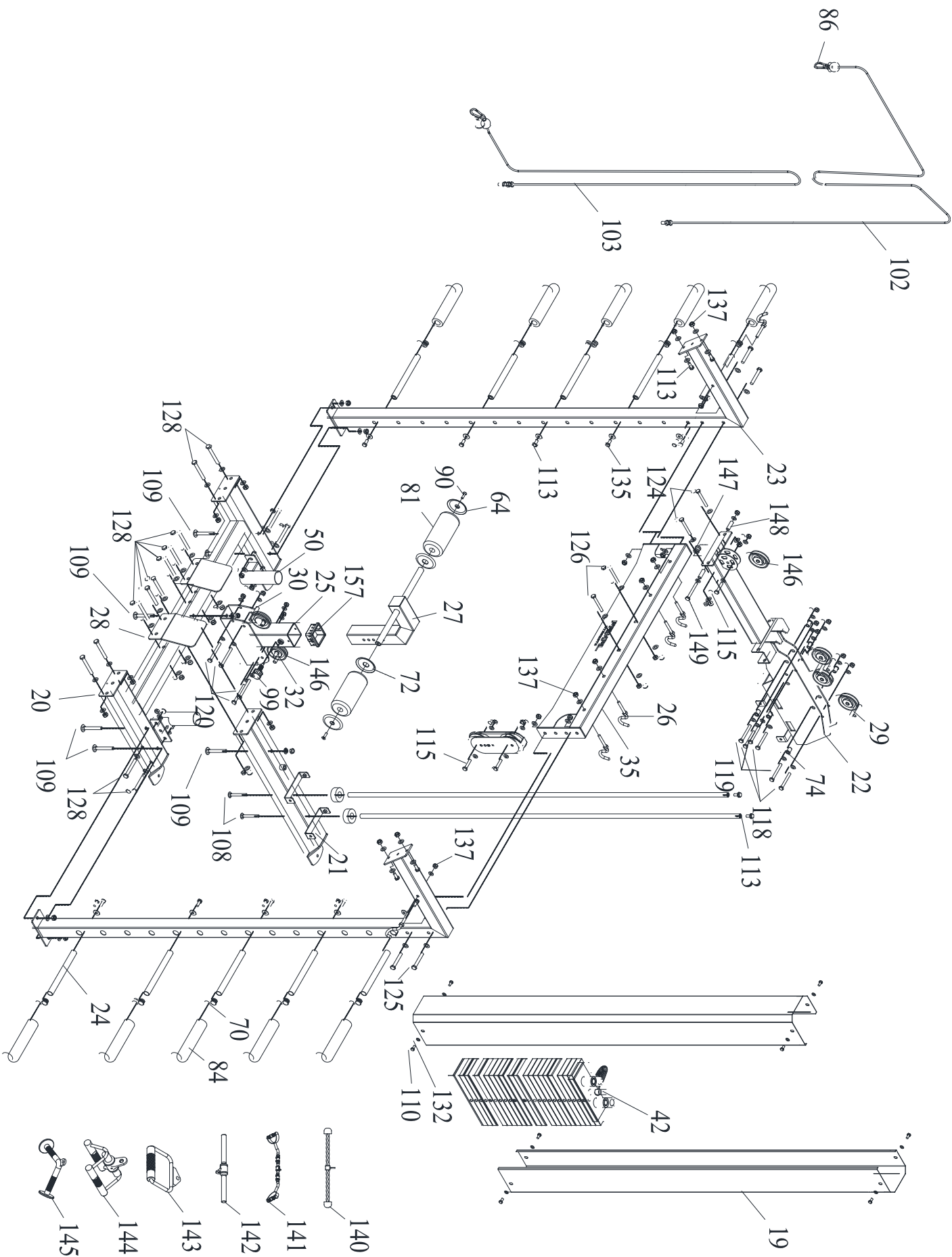

02/ASSEMBLY PROCEDURE

1) Step 1

Bill of materials			
No.	Name	Specification	Qty
1	Right bottom tube	Weldment	1
2	Left bottom tube	Weldment	1
4	upright	Weldment	2
5	Upright	Weldment	2
10	Guide rod	Weldment	4
43	Handle	Weldment	2
47	Small rod	φ20*50	24
76	Rubber Bumper	φ50*φ22*45	4
108	Carriage bolt	M10*85	4
109	Carriage bolt	M12*95	8
116	Hexagon socket cylinder head bolt	M10*70	4
117	Hexagon socket cylinder head bolt	M10*75	24
133	Flat washer	Φ10	8
134	Flat washer	Φ12	8
135	Large flat washer	Φ10	24
137	Hexagon lock nut	M10	4
138	Hexagon lock nut	M12	8

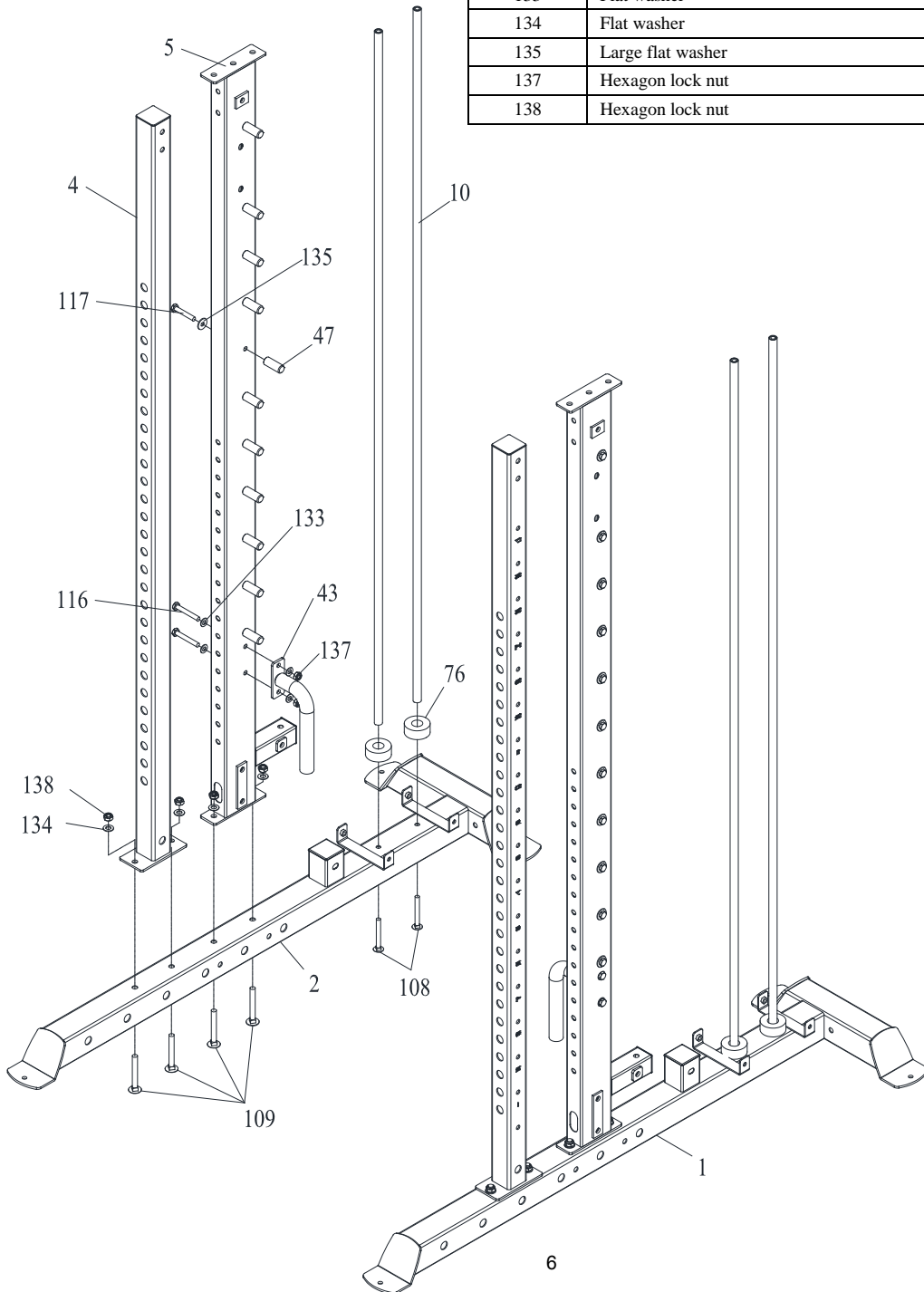

2) Step 2

Bill of materials			
No.	Name	Specification	Qty
3	Checkered plate	T6*200*1227	1
10	Guide rod assembly	Weldment	2
20	Rear bottom tube 1	Weldment	1
21	Rear bottom tube 2	Weldment	1
23	Rear upright	Weldment	2
25	Handle bracket	Weldment	1
30	Cable bumping post 2	Round tube $\phi 14*1.5*72$	2
32	Idler wheel fixed leg	Round tube $\phi 14*1.5*29$	4
76	Crash pad	$\phi 50*\phi 22*45$	2
108	Carriage bolt	M10*85	2
109	Carriage bolt	M12*95	6
120	Hexagon socket cylinder head bolt	M10*100	4
128	Hexagon socket cylinder head bolt	M12*95	10
133	Flat washer	$\Phi 10$	8
134	Flat washer	$\Phi 12$	26
137	Hexagon lock nut	M10	4
138	Hexagon lock nut	M12	16
146	Aluminum pulley	$\Phi 90$	2

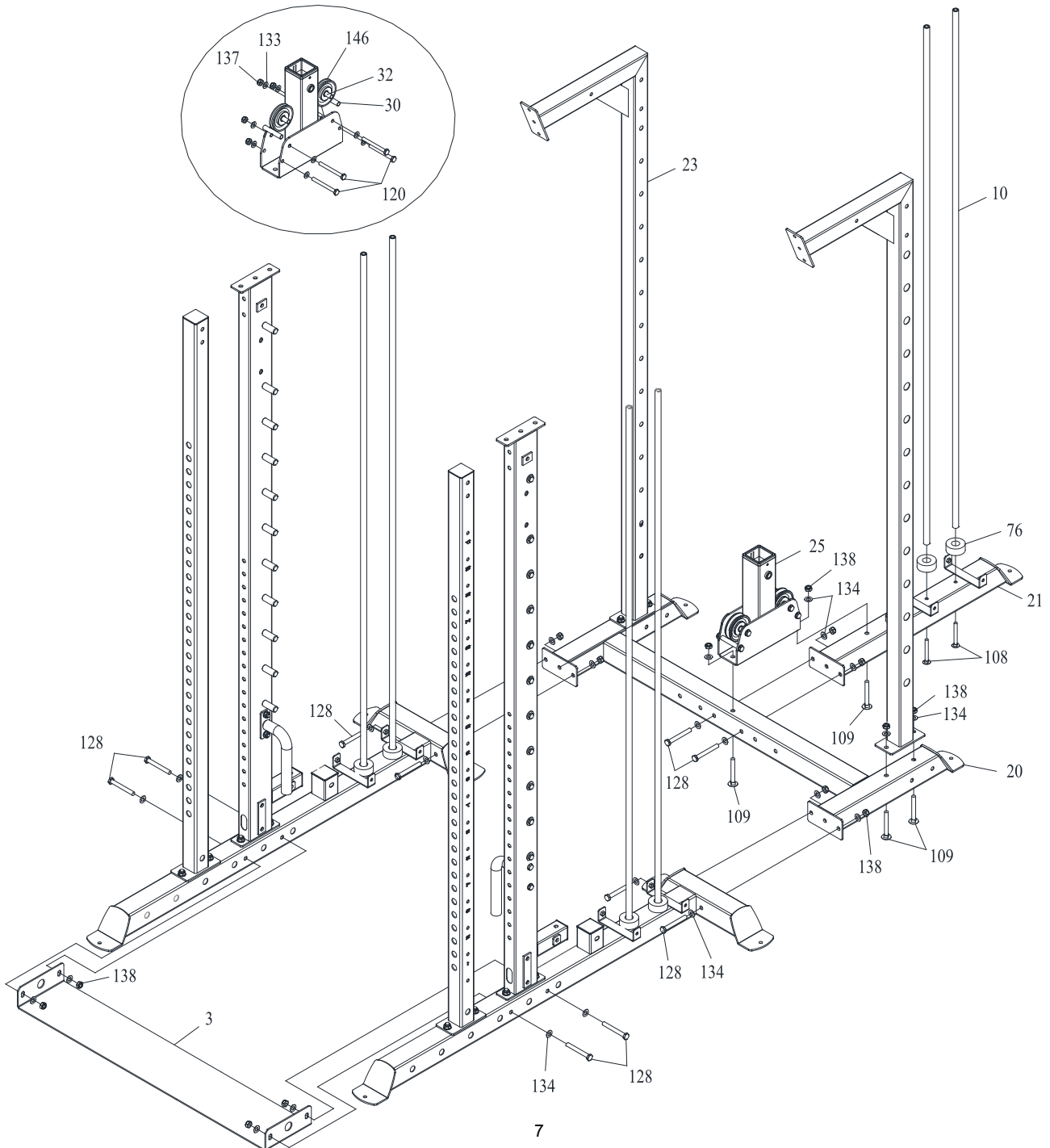

3) Step 3

Bill of materials			
No.	Name	Specification	Qty
33	Sliding block	Weldment	2
42	Weight stack selector A		1
52	Weight stack selector B		2
83	Aluminum pulley	Φ114	2
89	Selector pin		3
94	Round-shaped shaft		3
95	Top plate		3
96	Weight stack		62
115	Hexagon socket cylinder head bolt	M10*50	2
133	Flat washer	Φ10	4
137	Hexagon lock nut	M10	2
139	Weight stack label		3
146	Aluminum pulley	Φ90	2

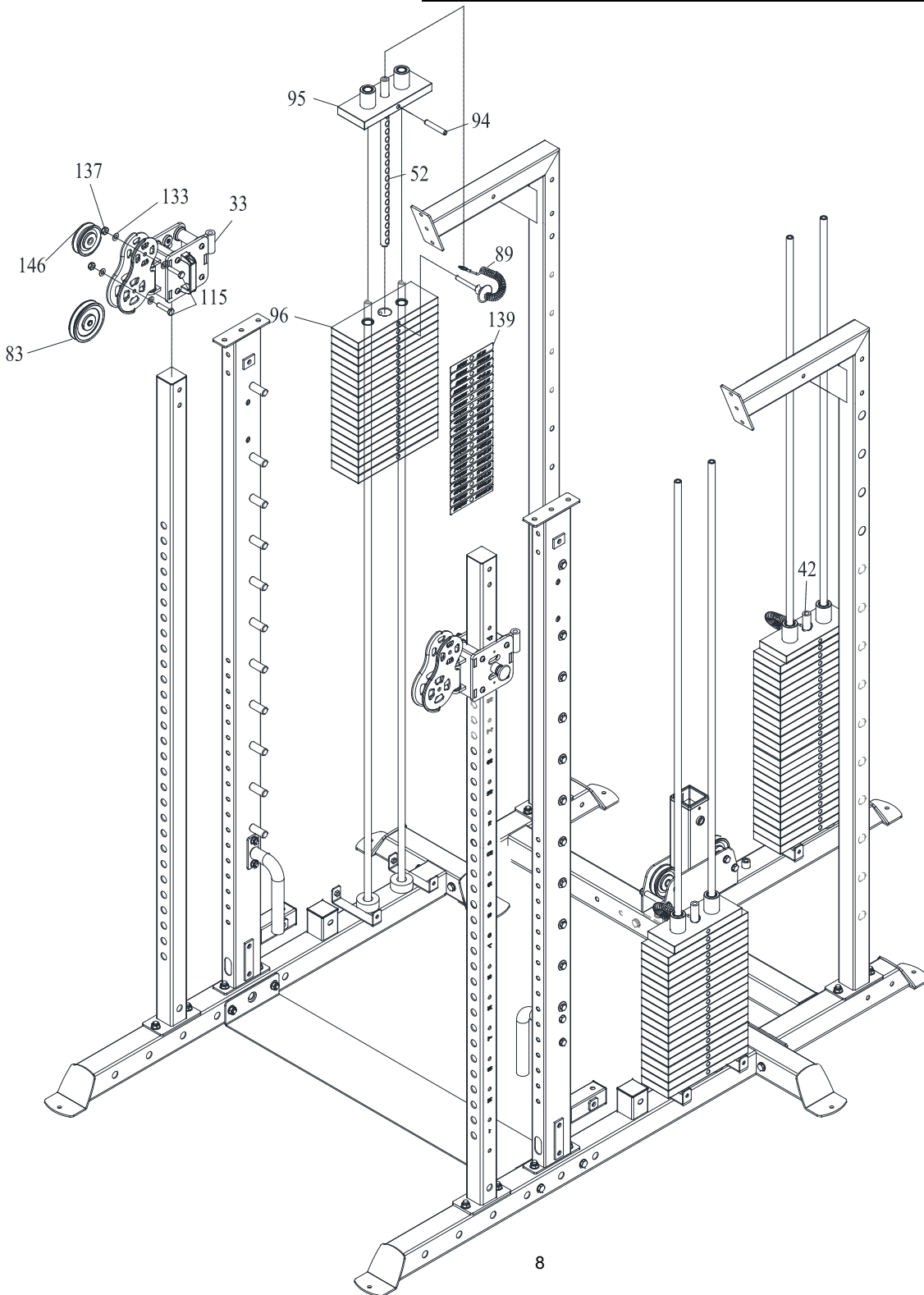

4) Step 4

Bill of materials			
No.	Name	Specification	Qty
11	Guide rod bracket	Weldment	2
12	LM shaft	$\phi 25 * 1929$	2
18	Buffer bracket	Weldment	2
76	Crash pad	$\phi 50 * \phi 22 * 45$	4
82	Rubber buffer ring	$\Phi 80 * \Phi 50 * T5$	2
99	Quick pull pin	$\text{Ø}38 * \text{M}16 * 1.5$	2
122	Hexagon socket cylinder head bolt	M12*25	2
123	Hexagon socket cylinder head bolt	M12*70	2
131	Hexagon socket cylinder head bolt	M12*120	4
134	Flat washer	$\Phi 12$	12
138	Hexagon lock nut	M12	4

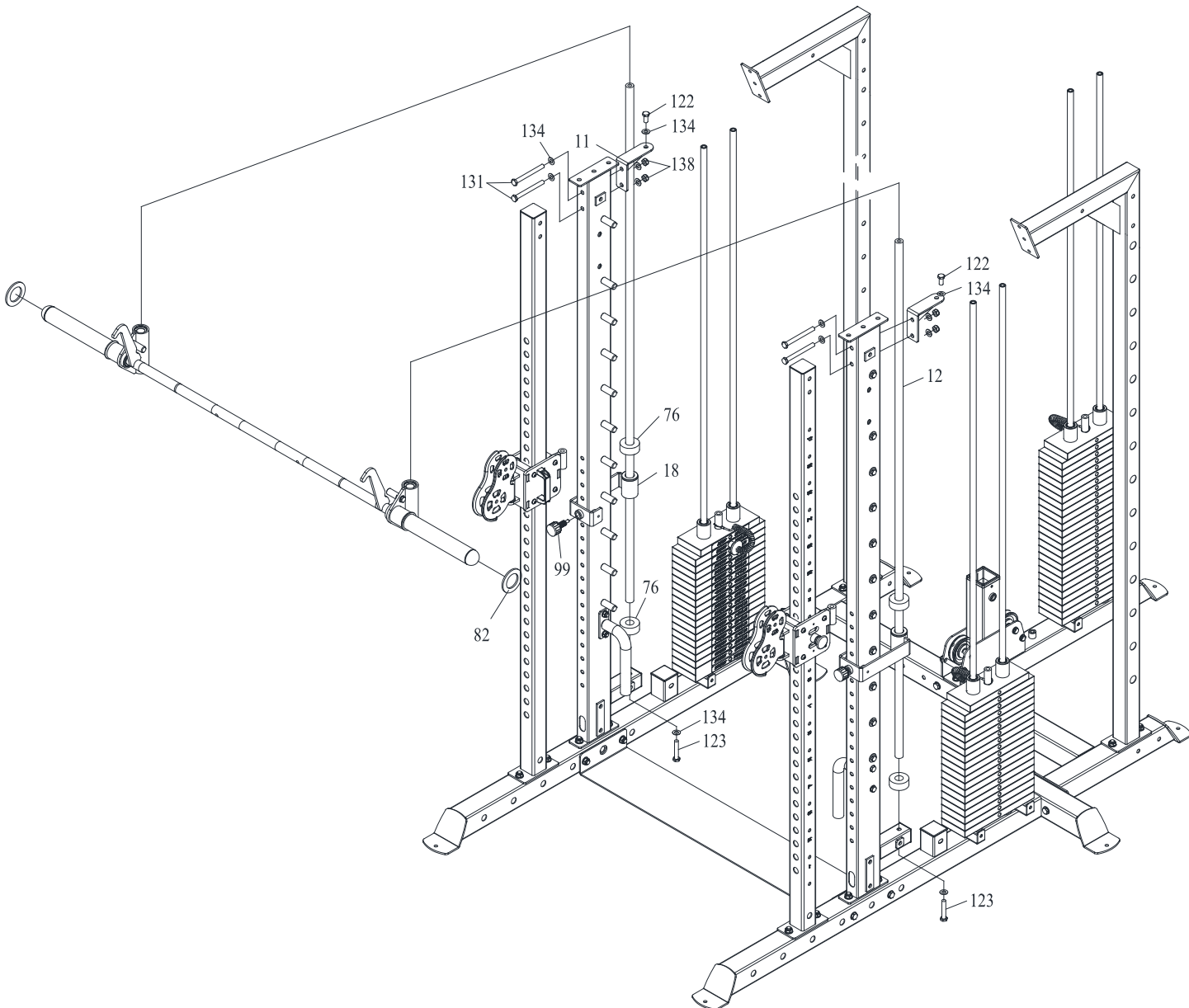

5) Step 5

Bill of materials			
No.	Name	Specification	Qty
6	Short frame	Weldment	2
26	Hook assembly	Weldment	2
29	Cable bumping post 1	Round tube $\phi 14 \times T1.5 \times 60$	8
74	Nylon bush	$\phi 16 \times 24$	16
113	Hexagon bolt	M10*25	4
118	Hexagon socket cylinder head bolt	M10*85	8
119	Hexagon socket cylinder head bolt	M10*90	8
126	Hexagon socket cylinder head bolt	M12*85	4
130	Hexagon socket cylinder head bolt	M12*80	4
133	Flat washer	$\phi 10$	36
134	Flat washer	$\phi 12$	16
137	Hexagon lock nut	M10	16
138	Hexagon lock nut	M12	8
146	Aluminum pulley	$\phi 90$	8

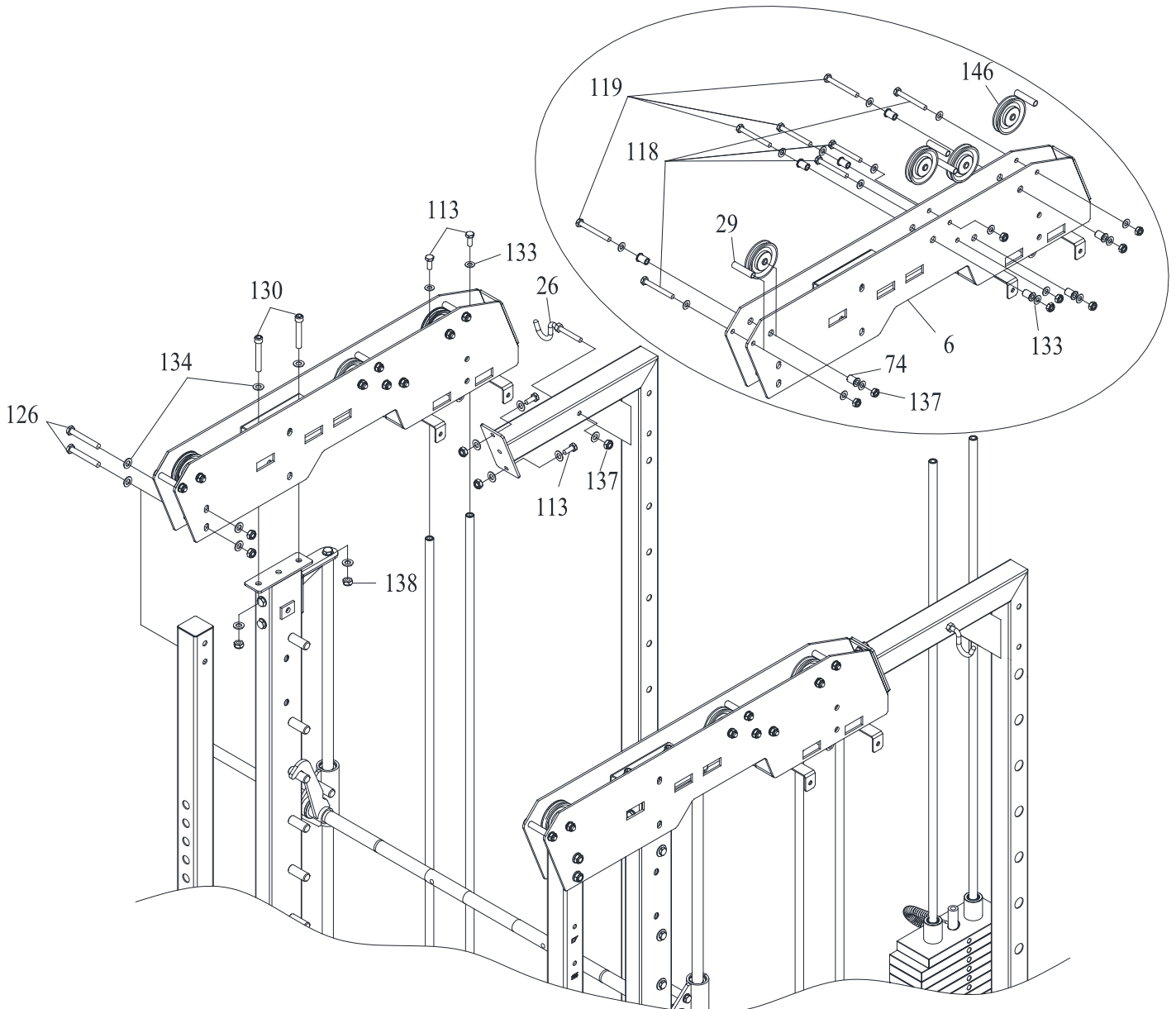

6) Step 6

Bill of materials			
No.	Name	Specification	Qty
7	Front upper connecting assembly	Weldment	1
8	Rear upper connecting assembly	Weldment	1
26	Hanger assembly	Weldment	4
35	Rear upper connecting assembly 2	Weldment	1
46	Chin-up frame	Weldment	1
54	Lifting hook	Round steel ϕ 12*314	1
125	Hexagon socket cylinder head bolt	M12*80	9
127	Hexagon socket cylinder head bolt	M12*90	8
133	Flat washer	Φ 10	6
134	Flat washer	Φ 12	34
137	Hexagon lock nut	M10	6
138	Hexagon lock nut	M12	17

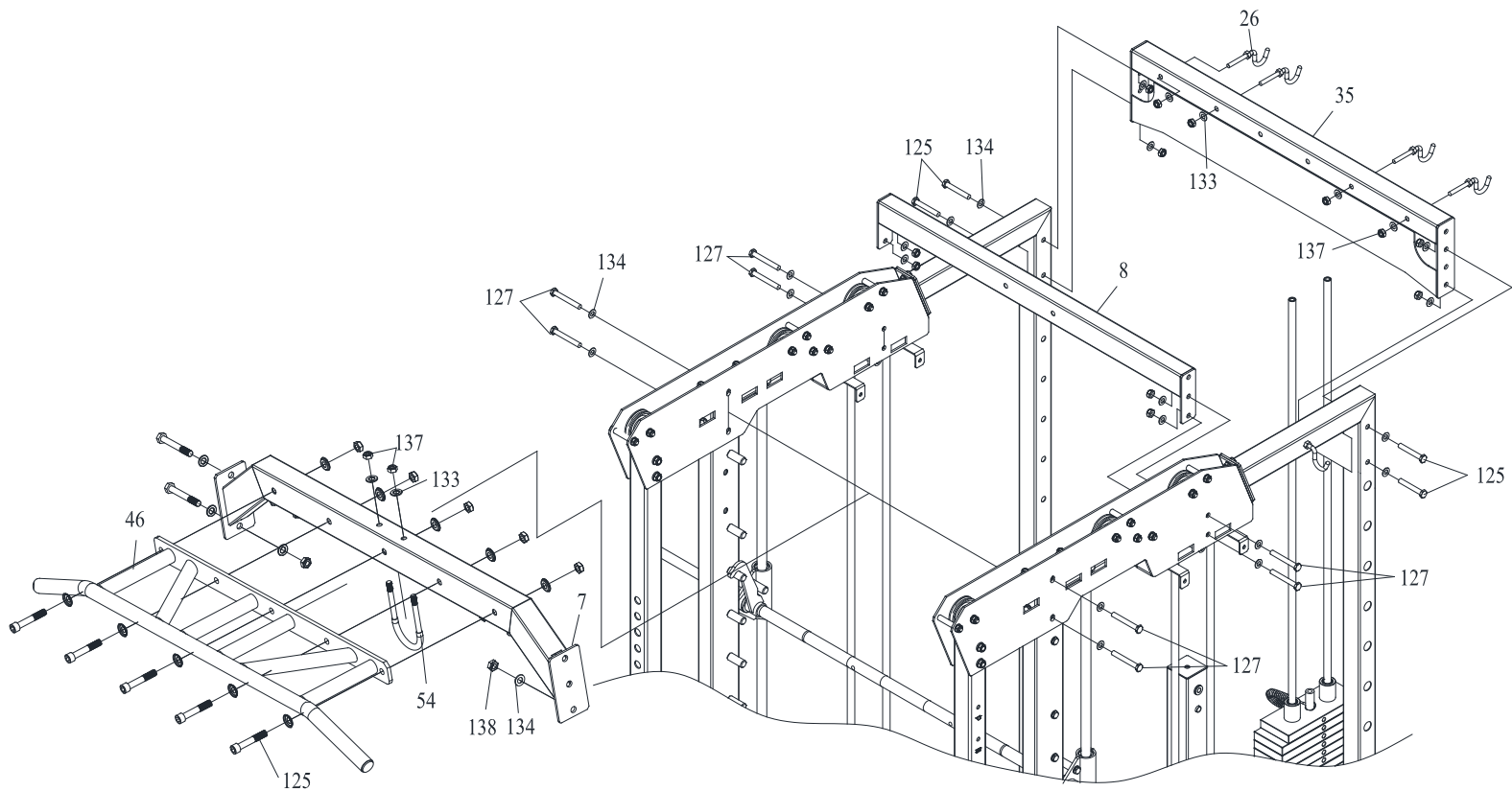

7) Step 7

Bill of materials			
No.	Name	Specification	Qty
22	Rear top beam assembly	Weldment	1
29	Cable bumping post	Round tube $\phi 14 * T 1.5 * 60$	3
74	Nylon bush	$\Phi 16 * 24$	6
113	Hexagon bolt	M10*25	2
115	Hexagon socket cylinder head bolt	M10*50	1
118	Hexagon socket cylinder head bolt	M10*85	3
119	Hexagon socket cylinder head bolt	M10*90	3
124	Hexagon socket cylinder head bolt	M12*70	2
126	Hexagon socket cylinder head bolt	M12*85	2
133	Flat washer	$\Phi 10$	18
134	Flat washer	$\Phi 12$	8
137	Hexagon lock nut	M10	8
138	Hexagon lock nut	M12	4
146	Aluminum pulley	$\Phi 90$	4
147	Small idler wheel	$\Phi 24$	1
148	Bumping post	Round tube $\phi 14 * 1.5 * 37$	2
149	Hexagon socket cylinder head bolt	M10*115	2

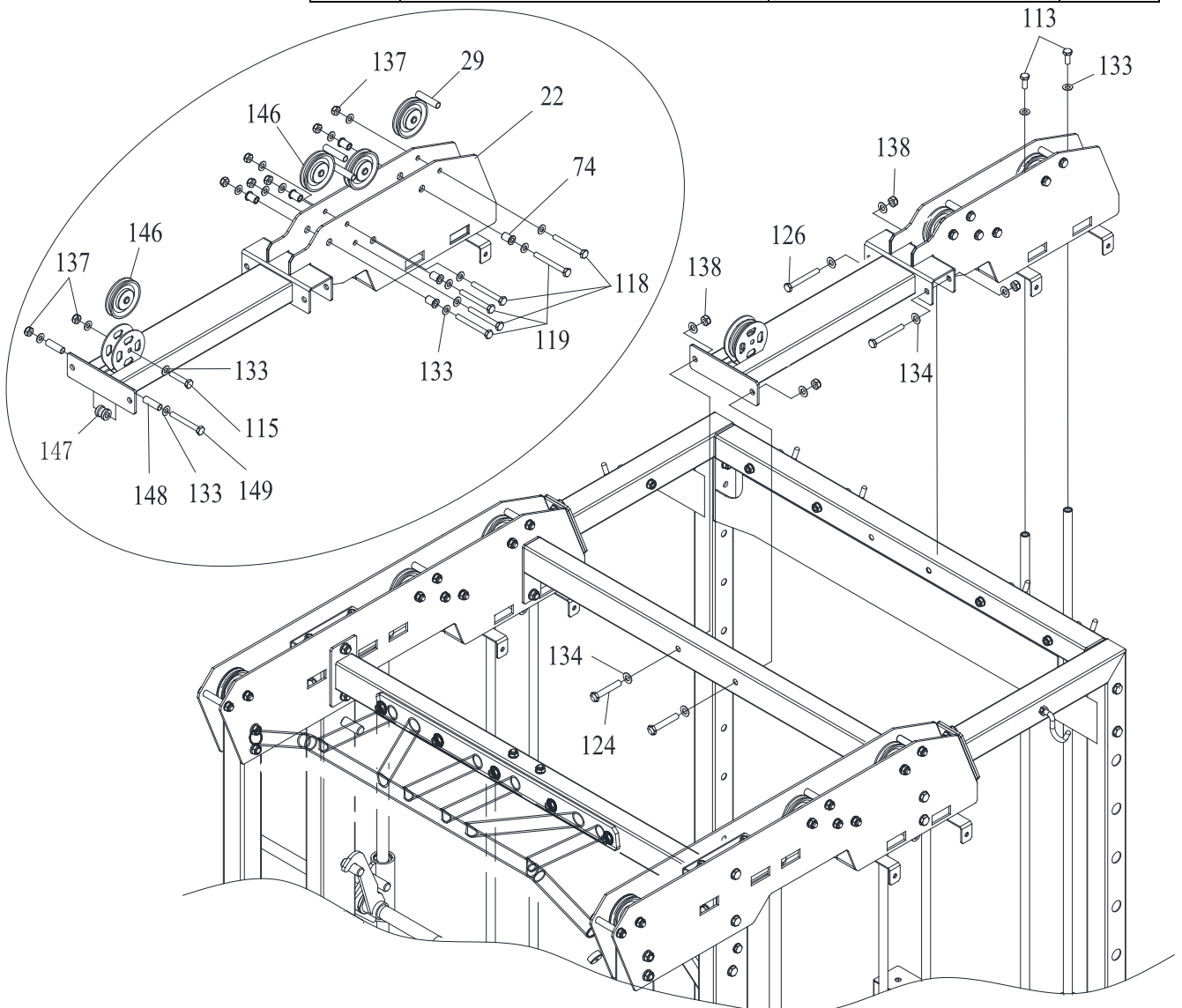

8) Step 8

Bill of materials			
No.	Name	Specification	Qty
9	Bottom pulley baffle	Steel plate T5*532.5*150	4
29	Cable bumping post 1	Round tube $\phi 14 \times T1.5 \times 60$	2
31	Bracket	Weldment	2
74	Nylon bush	$\Phi 16 \times 24$	8
118	Hexagon socket cylinder head bolt	M10*85	4
119	Hexagon socket cylinder head bolt	M10*90	4
126	Hexagon socket cylinder head bolt	M12*85	8
133	Flat washer	$\Phi 10$	16
134	Flat washer	$\Phi 12$	16
137	Hexagon lock nut	M10	8
138	Hexagon lock nut	M12	8
146	Aluminum pulley	$\Phi 90$	4

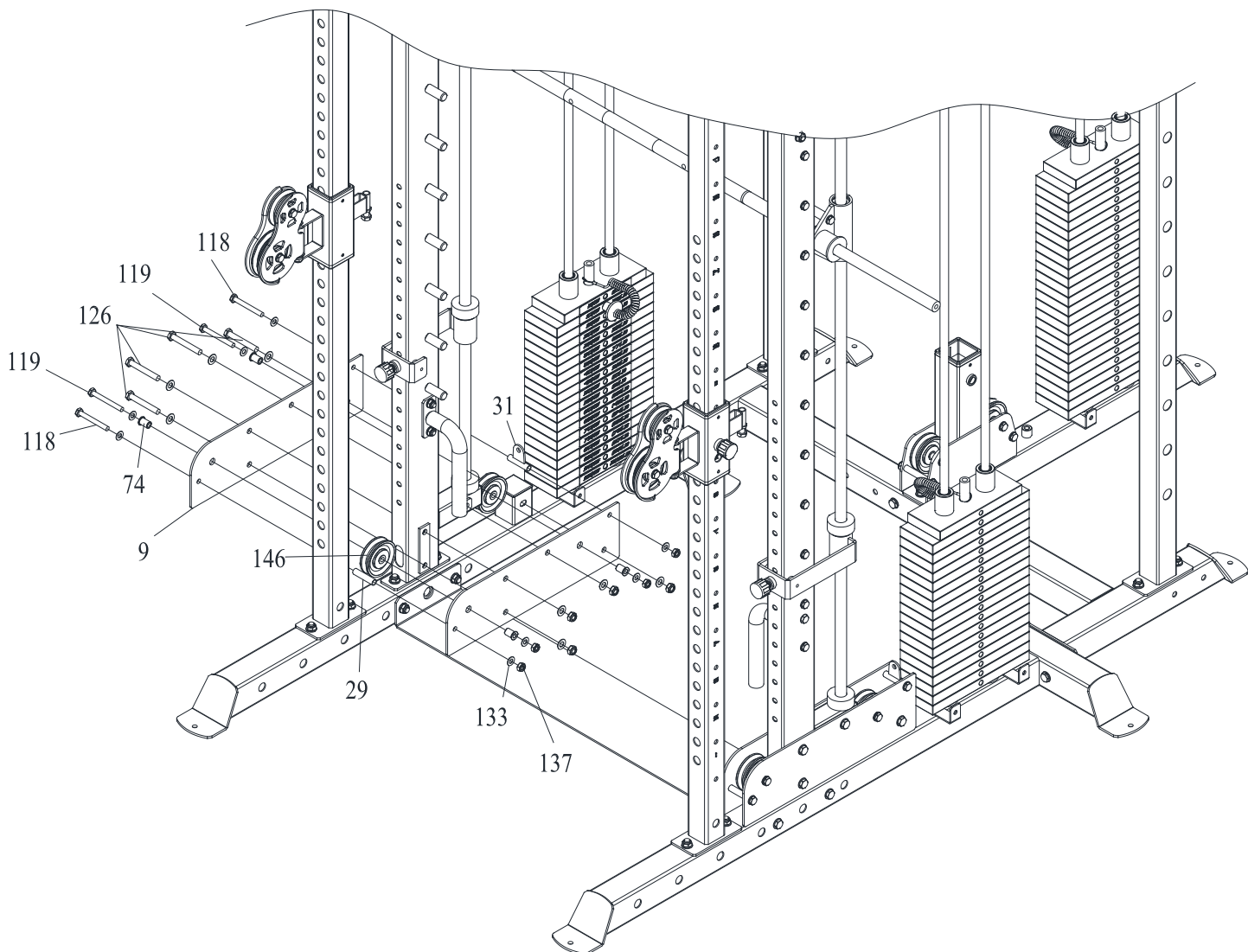

9) Step 9

Bill of materials			
No.	Name	Specification	Qty
27	Adjustable foam rod	Weldment	1
28	Checkered plate	T6*150*219	2
50	Annular tube	Weldment	2
64	Foam end cover	Φ90*6	2
72	Φ90 foam end cover	Φ90*6	2
81	Foam(black)	Φ23*Φ90*190	2
90	Hexagon socket countersunk bolt	M8*20	2
99	Quick pull pin	Ø38*M16*1.5	1
128	Hexagon socket cylinder head bolt	M12*95	8
134	Flat washer	Φ12	16
138	Hexagon lock nut	M12	8

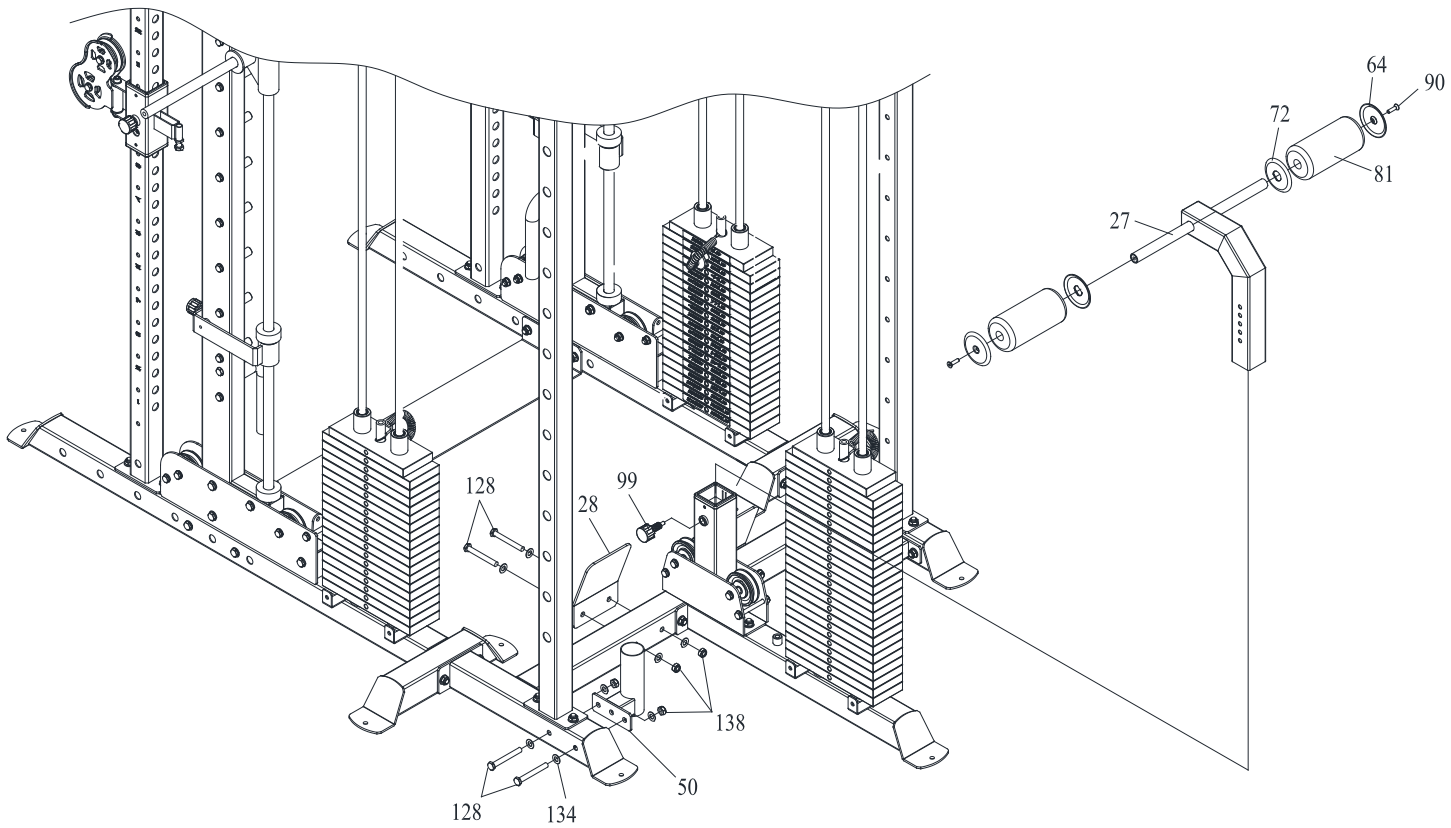

10) Step 10

Bill of materials			
No.	Name	Specification	Qty
53	Pulley frame	Weldment	3
73	Pulley seat	Weldment	2
100	SWC08 Cable 3	Φ5*6955	2
101	SWC08 Cable 4	Φ5*3220	2
102	SWC08 Cable 1	Φ5*3875	1
103	SWC08 Cable 2	Φ5*3190	1
112	Hexagon socket cylinder head bolt	M10*25	2
115	Hexagon socket cylinder head bolt	M10*50	8
133	Flat washer	Φ10	24
137	Hexagon lock nut	M10	12
146	Aluminum pulley	Φ90	8
152	Hexagon socket cylinder head bolt	M10*30	2
153	Hexagon lock nut	M12	2

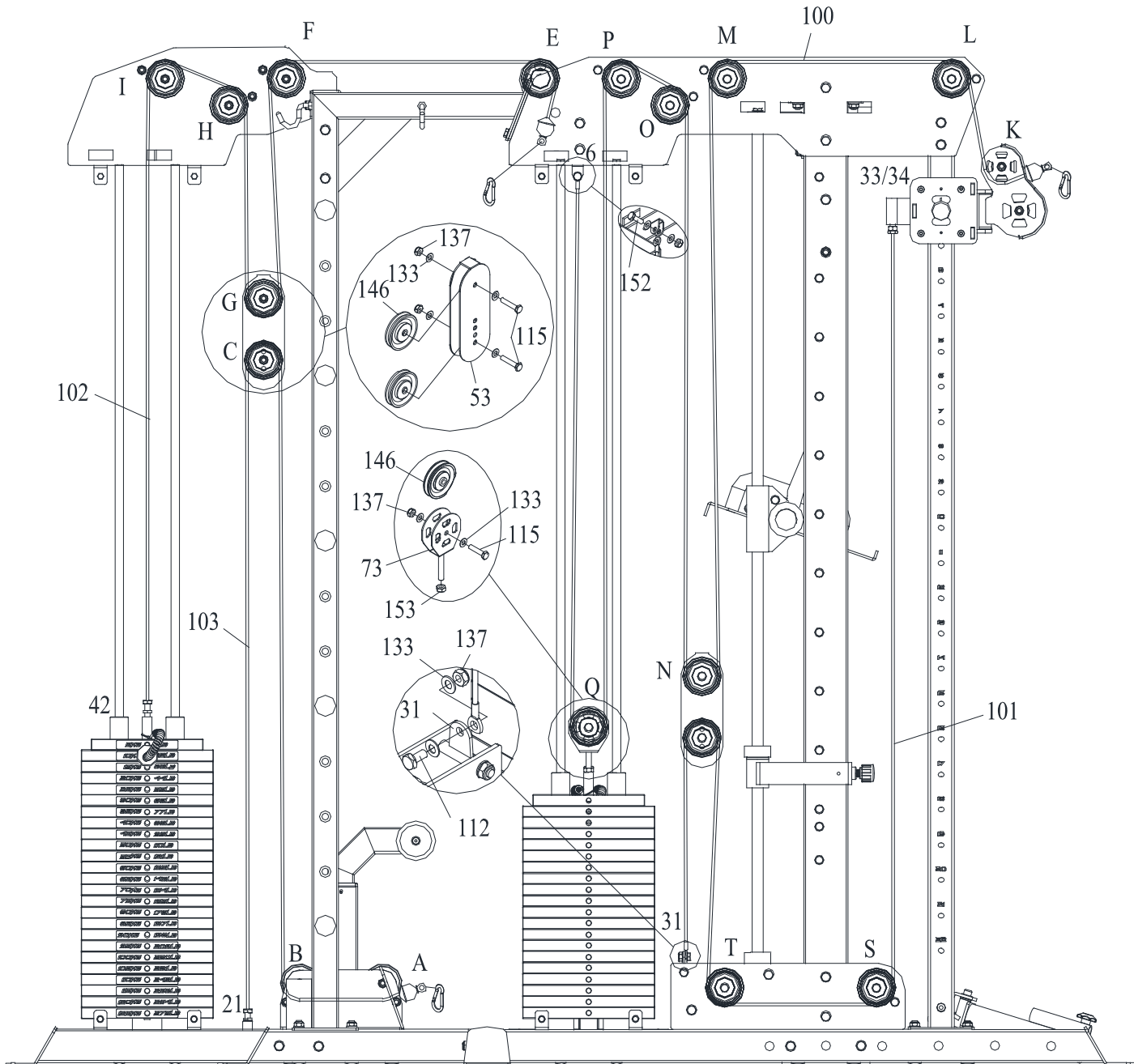

11) Step 11

Bill of materials			
No.	Name	Specification	Qty
19	Shroud	T1*1963*484.2	6
24	Weight plate rod	Weldment	10
84	Barbell sleeve	Φ25*Φ50*230	10
110	Hexagon socket cylinder head bolt	M8*16	24
113	Hexagon socket cylinder head bolt	M10*25	10
132	Flat washer	Φ8	24
135	Large Flat washer	Φ10	10

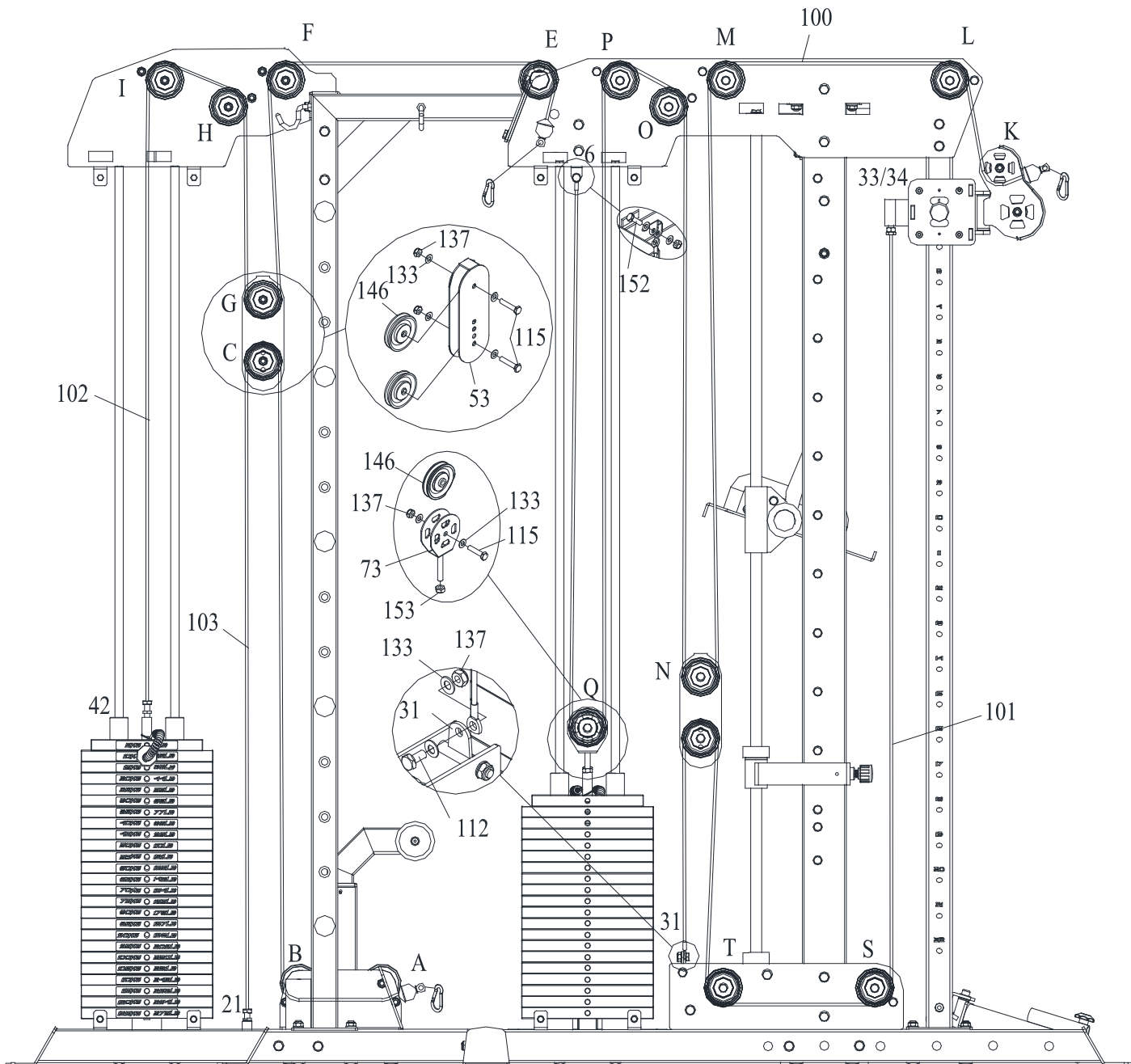

12) Step 12

Bill of materials			
No.	Name	Specification	Qty
57	Footboard assembly	Weldment	1
88	L-shaped latch	Φ10*70	2

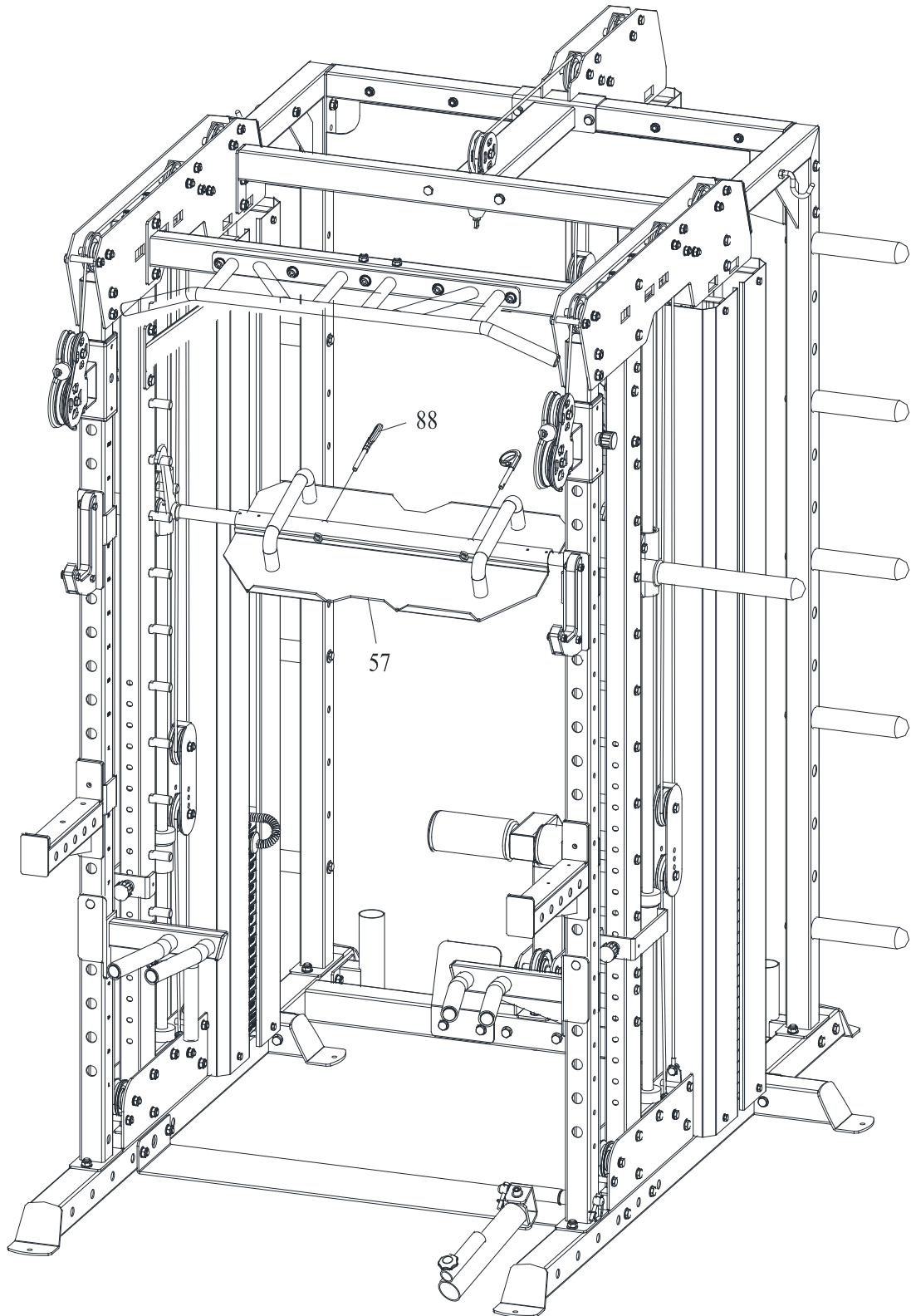

03/ PRODUCT DESCRIPTION

The machine is for indoor fitness equipment use. It is suitable for anaerobic exercise, mainly used to train the total body muscles while improving cardio-pulmonary functions. Working out with the machine will enhance overall muscularity.

Users can adjust the resistance by weight stack easily.

The design and manufacture of the machine meets the human anatomy while the safety and durability are very important for the users.

The design and manufacture of the machine meets the human motion curve, and meets the standard of specifications of GB17498.1-2008 and GB17498.2-2008. The durability is guaranteed.

Large size steel tube and electrostatic spraying guarantee the safety and durability.

04/ PRODUCT PARAMETER

Name: Megatron Deluxe Model SM-12

Floor space 2600mm x 1900mm x 2350mm, 102 in x 75 in x 93 in.

Weight stacks(3), 90 Kg each/(200 lbs each)

Net Weight Kg Level S

05/ MAINTENANCE GUIDELINE

1. All the bolts and screws should be inspected regularly and kept tightened, and rotating parts should be flexible without abnormal noise.
2. The machine should be kept clean. Please DO NOT clean the machine with strong cleaning solvent.
3. Any worn or damaged stressed parts should be repaired or changed immediately.

06/ TROUBLESHOOTING

07/ WARRANTY INSTRUCTION

1. Warranty scope

The machine is not cover for damages by any misuse while under proper maintenance. The warranty card is valid only for the original buyer.

2. The warranty period is one year after purchase of the machine.

3. The below-listed damages are out of warranty:

- 1). damages caused by abuse, carelessness, accident or unauthorized modify.
- 2). damages caused by improper adjustment of weight stack pins.
- 3). damages caused by improper maintenance.
- 4). damages caused by other improper operations of the machine.