

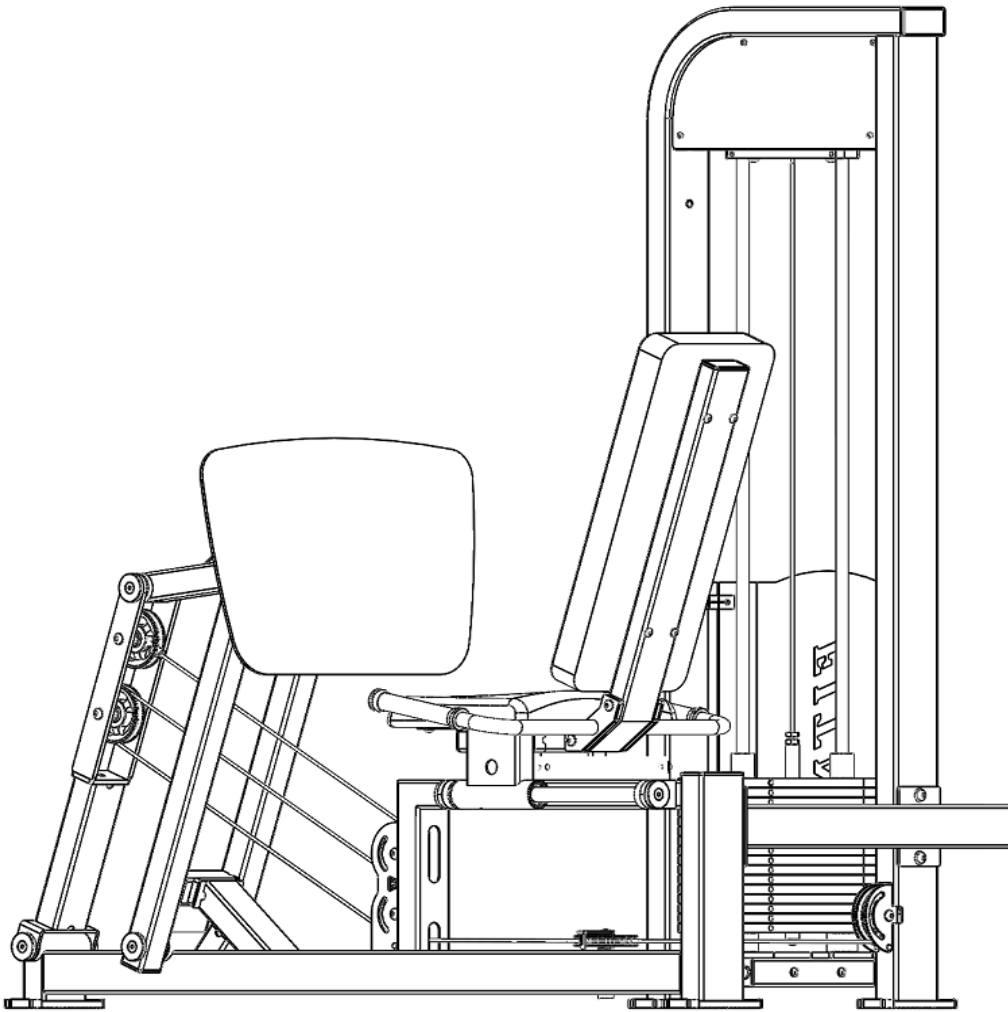









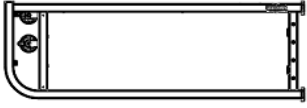
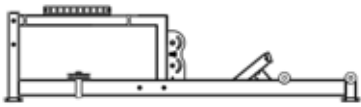

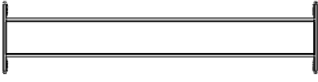





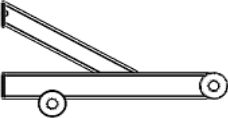

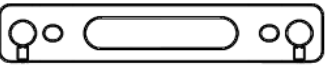



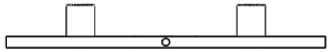

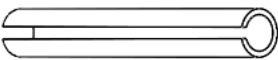
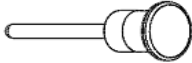

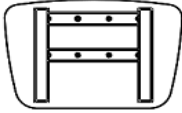





# Excel Horizontal Leg Press (S-EX-HLP)

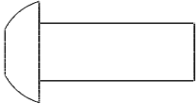

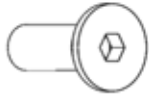
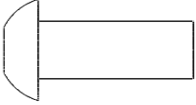
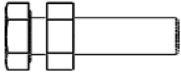
[WWW.MUSCLEDFIT.COM](http://WWW.MUSCLEDFIT.COM)

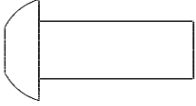
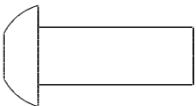
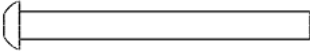
## Parts list (individually packaged)

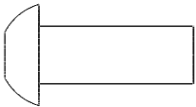
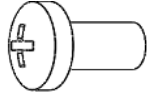
					
NO.1	Small door welding group*1	NO.2	Main frame welding group*1	NO.3	Upper connection welding group*1
					
NO.4	Lower connection welding group*1	NO.5	aluminum alloy flat end cap*12	NO.6	2004 Galvanized shaft*1
					
NO.7	2003 movable arm shaft*2	NO.8	2007 galvanized shaft*1	NO.9	Movable arm welding set*1
					
NO.10	Front arm welding set*1	NO.11	Foot connection welding set*1	NO.12	6001 small mount*1
					
NO.13	6011 optical axis fixing plate*1	NO.14	2002 guide rod*2	NO.15	15 hole weight adjustment rod*1
					
NO.16	0316 Lock Rope Column*1	NO.17	Long counterweight head set*1	NO.18	Weight stack
					
NO.19	0611 Counterweight rubber column*2	NO.20	10*70C cotter pin*1	NO.21	pull pin*1

					
NO.22	Pedal welding group*1	NO.23	Round shock absorbing pad*4	NO.24	sliding axis*2
					
NO.25	Cushion back welding group*1	NO.26	large backrest*1	NO.27	Cushion*1
					
NO.28	Label Edition*2	NO.29	Cover*1		
<b>Blister Pack List</b>					
					
A	M10*25 flat head screw*8	B	Φ10 flat washer*28	C	M10*25 flat countersunk head screw*12
					
D	M8*20 round head screw*4	E	M12*45 hexagon head hollow screw nut*1	F	M8*12 top wire*4
					
G	M10*30 flat head screw*2	H	M10*20 flat head screw*8	I	M8*70 round head screw*4
					
J	Φ8 flat washer*8	K	M8*25 round head screw*4	L	Cross recessed pan head screw M5*10*12
					
M	Φ5 flat washer*12				

## Assembly steps

Step	Item No.	Name	Quantity	Item No.	Name	Quantity
	NO.1	Small door welding group	1	A	M10*25 flat head screw	8
	NO.2	Main frame welding group	1	B	Φ10 flat washer	8
	NO.3	Upper connection welding group	1			
	NO.4	Lower connection welding group	1			

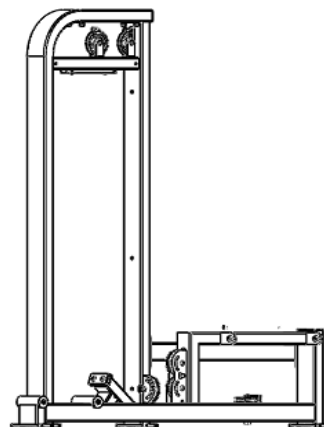
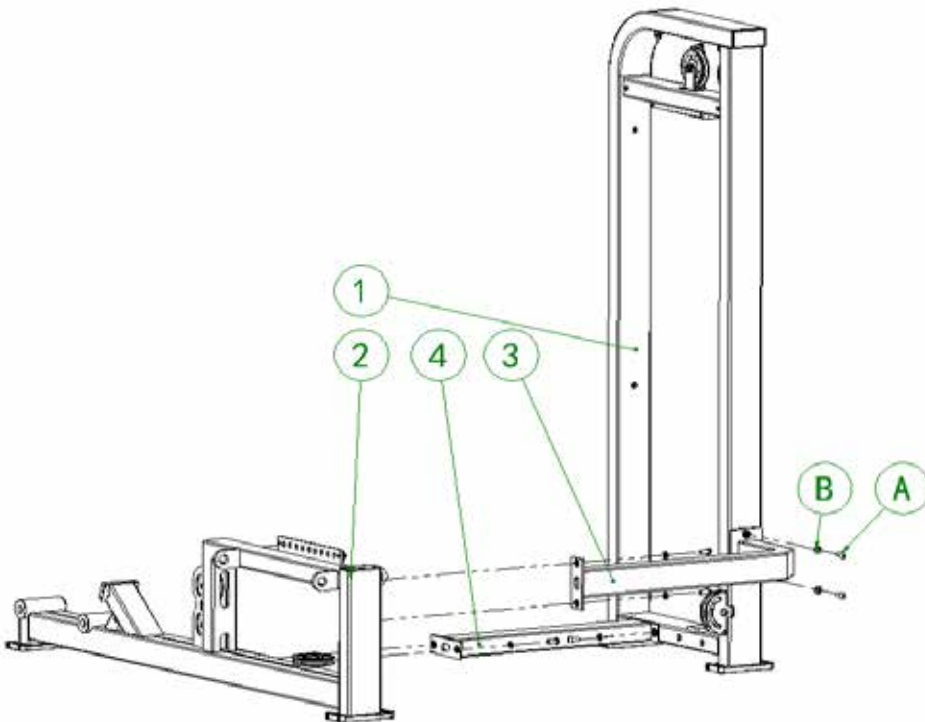

## NO.1 Small door welding group \*1

Step	Item No.	Name	Quantity	Item No.	Name	Quantity
	NO.30	pulley card rope set	2	B	Φ10 flat washer	4
	NO.31	105 Pulley	3	O	Hexagonal rivet nut M8	6
	NO.32	pulley pin	1	P	Hex rivet nut M10	8
	NO.33	Foot cover	2	Q	M10 lock nut	3
	NO.55	Square tube plug 50*100		N	M10*45 flat head screw	3

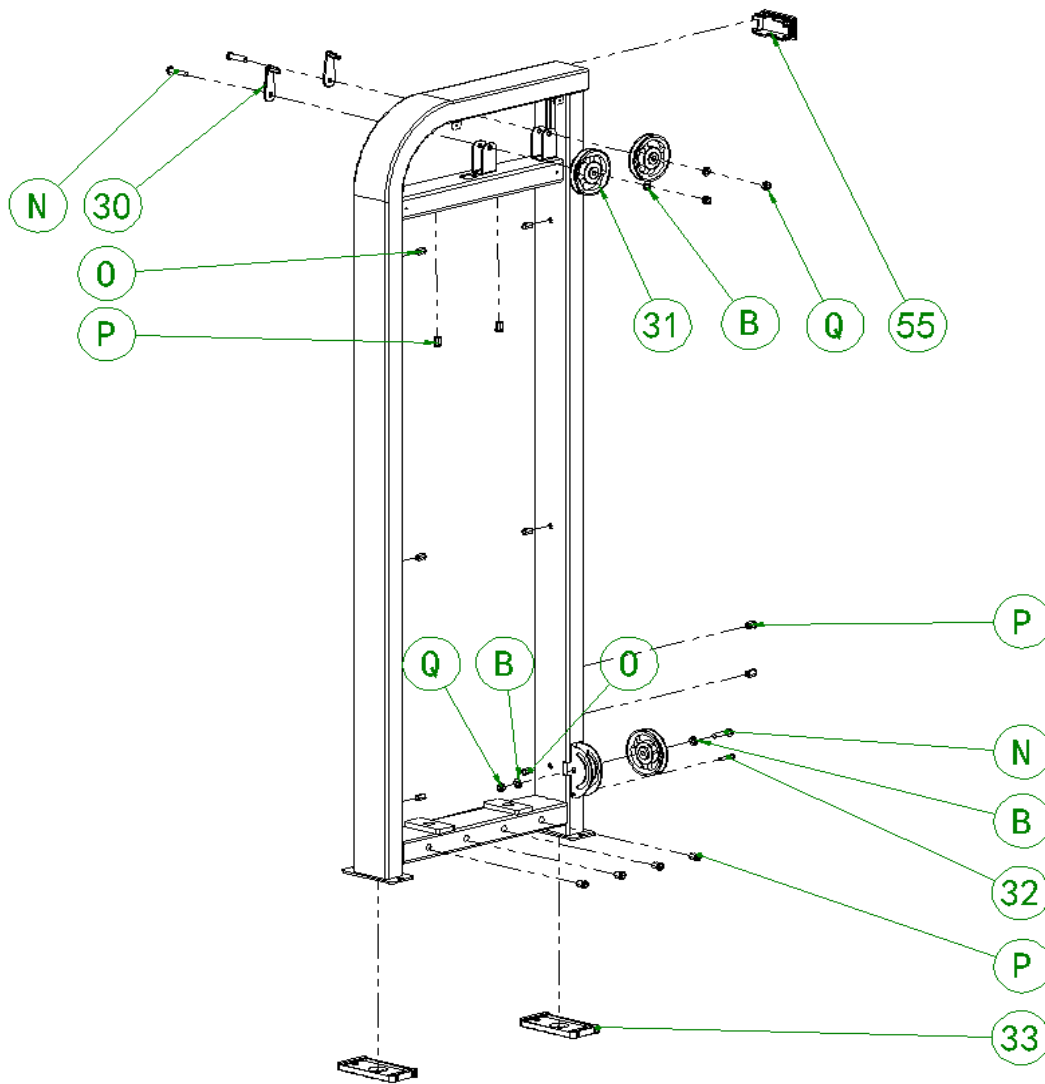

## No.2 Main frame welding group\*1

Step	Item No.	Name	Quantity	Item No.	Name	Quantity
	NO.30	pulley card rope set	1	B	Φ10 flat washer	4
	NO.31	105 Pulley	3	N	M10*45 flat head screw	3
	NO.33	Foot cover	2	P	Hex rivet nut M10	4
	NO.34	Stainless steel adjustment plate	1	Q	M10 lock nut	2
	NO.35	Polypropylene spacer	4	R	M8*10 cylinder head screw	2
	NO.36	Deep Groove Ball Bearings	4	V	M10*16 flat head screw	2
	NO.54	Thin shock pad 15mm	1	NO.55	Square tube plug 50*100	1
	NO.32	pulley pin	1			

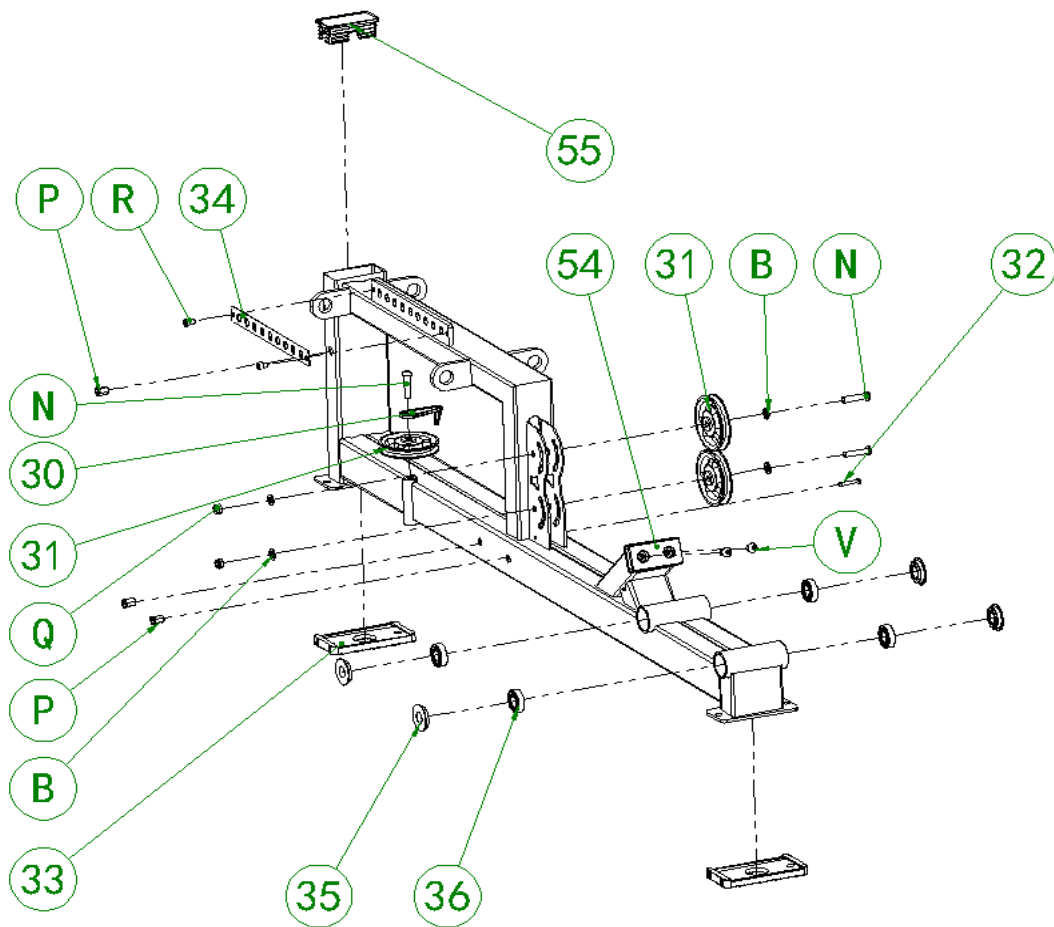

## Assembly steps

Step	Item No.	Name	Quantity	Item No.	Name	Quantity
2	NO.5	aluminum alloy flat end cap	8	NO.10	Front arm welding set	4
	NO.6	2004 Galvanized shaft	1	NO.11	Foot connection welding set	4
	NO.7	2003 movable arm shaft	2	C	M10*25 flat countersunk head screw	8
	NO.8	2007 galvanized shaft	1			
	NO.9	Movable arm welding set	4			

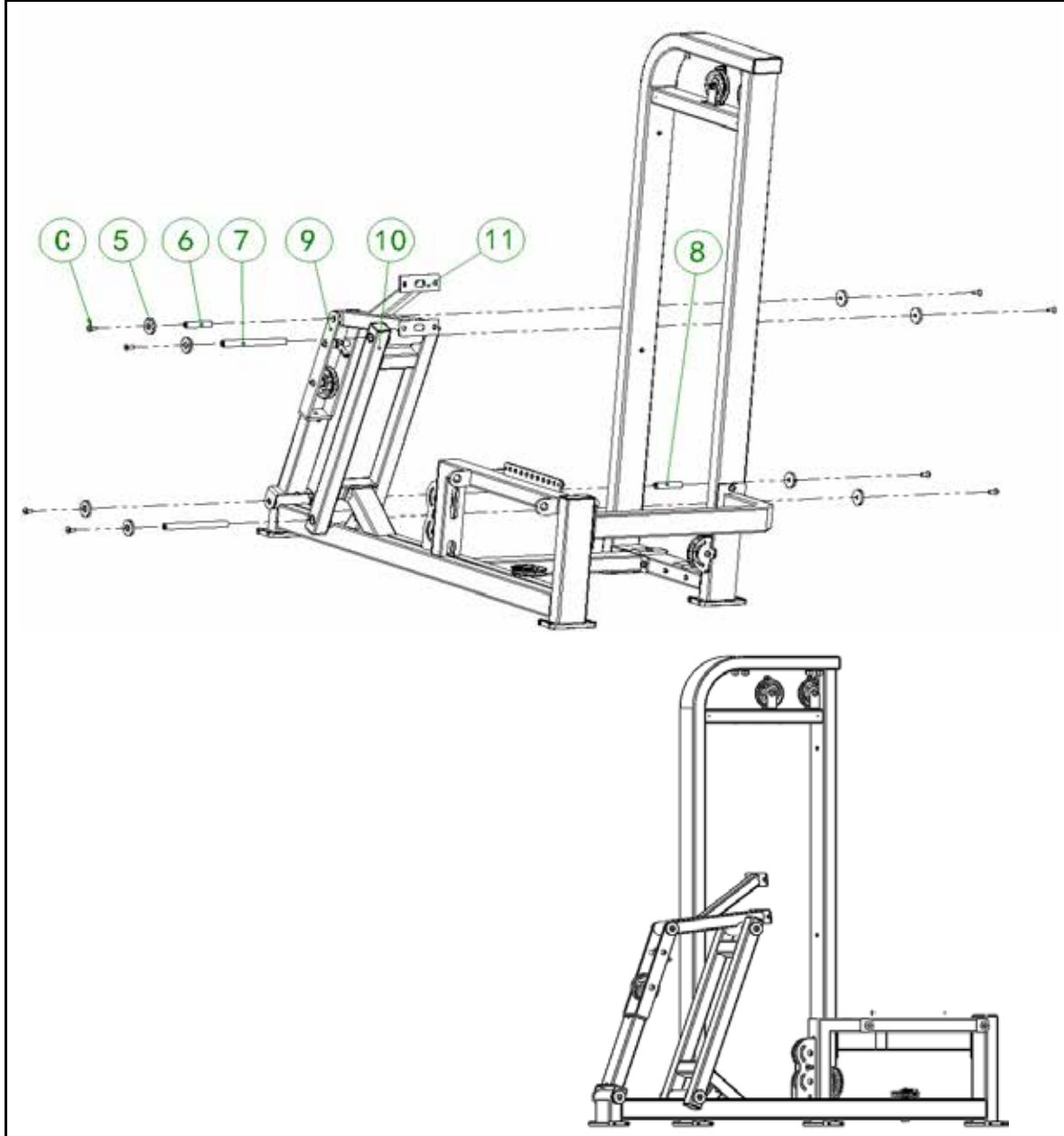

## NO.9 Movable arm welding set\*1

Step	Item No.	Name	Quantity	Item No.	Name	Quantity
	NO.31	105 Pulley	1	B	Φ10 flat washer	4
	NO.37	2002 Spacer	4	Q	M10 lock nut	2
	NO.38	GT003	2	S	M10*105 flat head screw	2
	NO.39	Joint bearing M10-8 positive buckle	1			

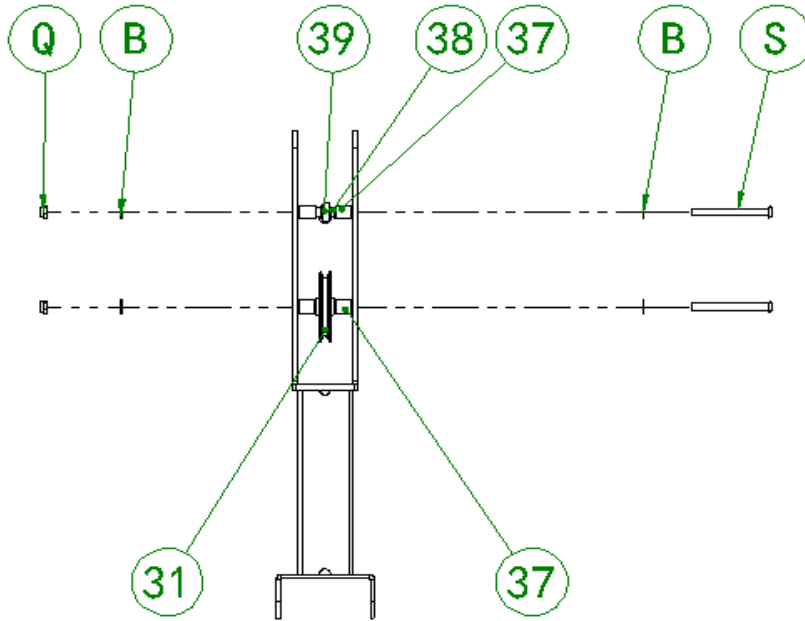

## NO.10 Front arm welding set\*1

Step	Item No.	Name	Quantity	Item No.	Name	Quantity
	NO.40	square pipe plug 50*50	4			

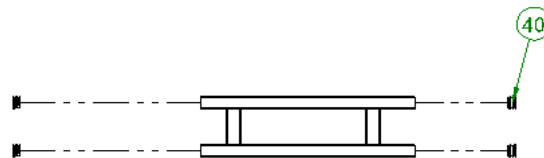

## NO.11 Foot connection welding set

Step	Item No.	Name	Quantity	Item No.	Name	Quantity
	NO.35	2013 Polypropylene spacer	4	NO.36	6004 deep groove ball bearings	4

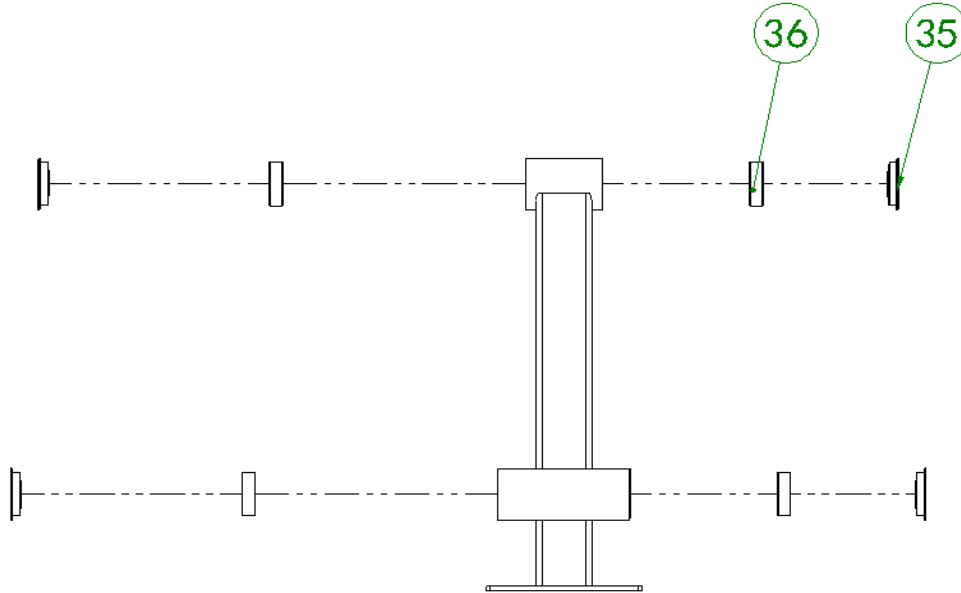

## Assembly steps

Step	Item No.	Name	Quantity	Item No.	Name	Quantity
<b>3</b>	NO.12	6001 small mount	4			
	D	M8*20 round head screw	4			

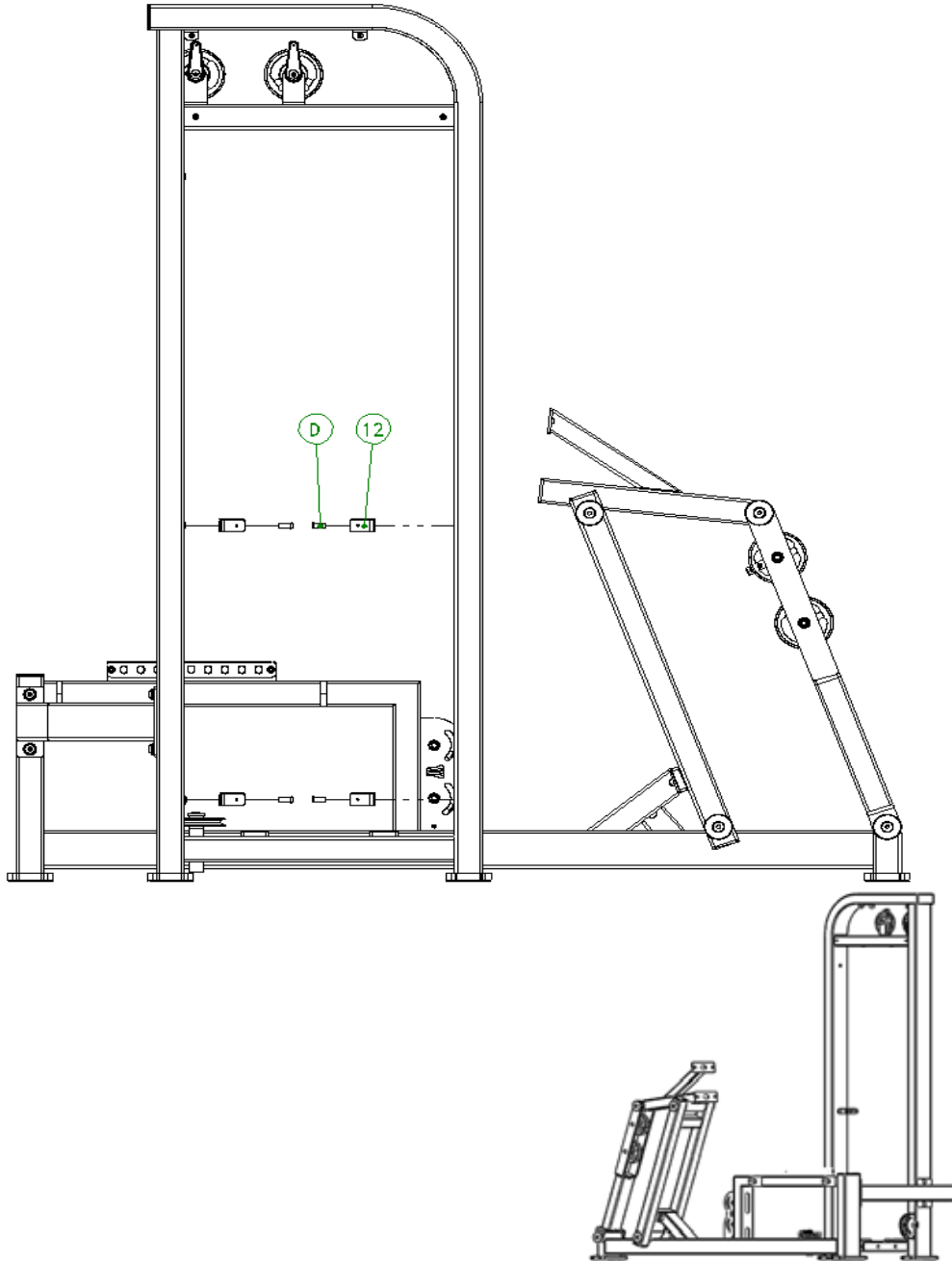

## Assembly steps

Step	Item No.	Name	Quantity	Item No.	Name	Quantity
<b>4</b>	NO.13	6011 optical axis fixing plate	1	NO.19	0611 Counterweight rubber column	2
	NO.14	2002 guide rod	2	NO.20	10*70C cotter pin	1
	NO.15	15 hole weight adjustment rod	1	NO.21	pull pin	1
	NO.16	0316 Lock Rope Column	1	E	M12*45 hexagon head hollow screw nut	1
	NO.17	Long counterweight head set	1	F	M8*12 top wire	2
	NO.18	Weight stack		G	M10*30 flat head screw	2

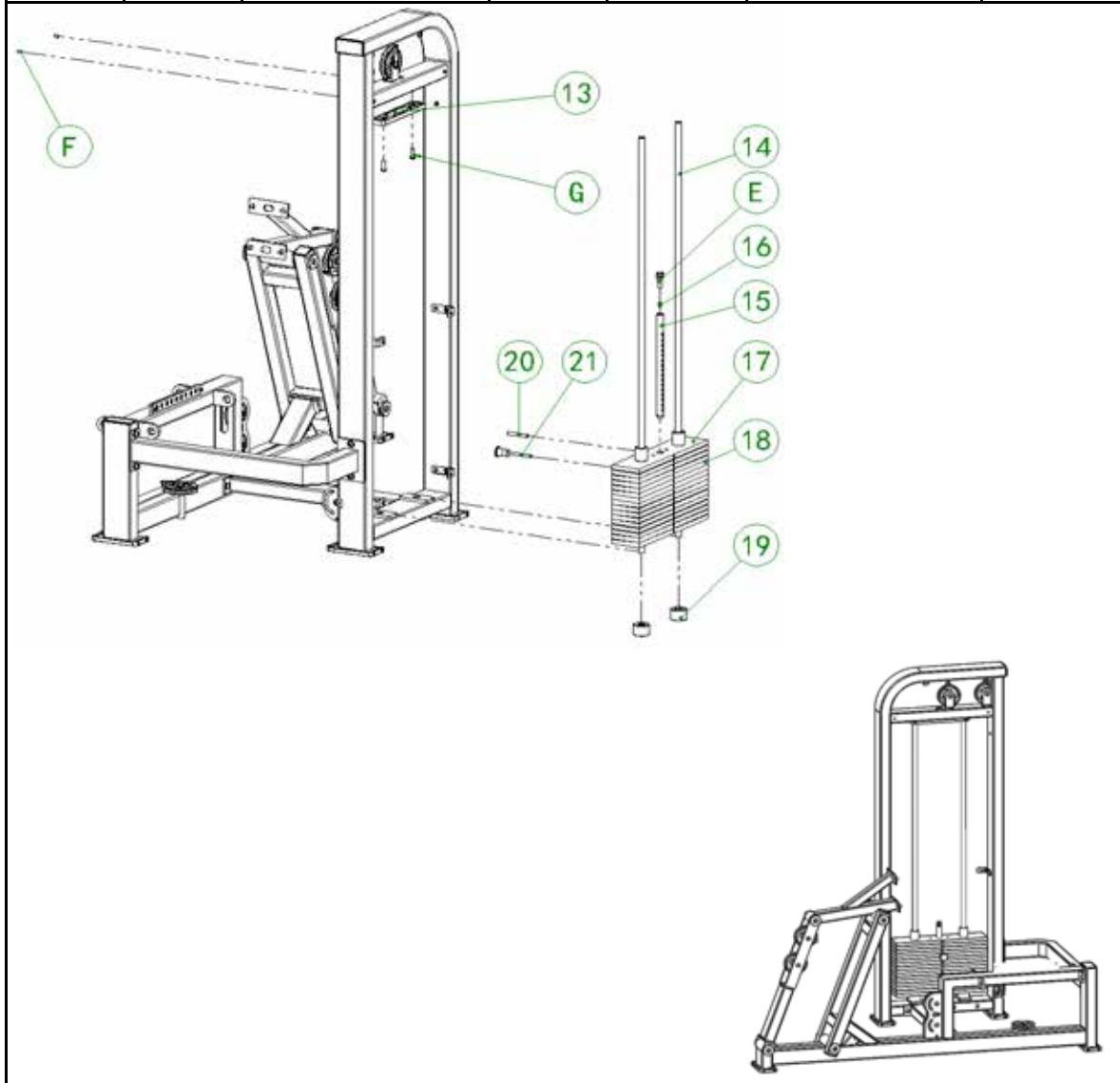

## NO.17 Long counterweight head se\*1

Step	Item No.	Name	Quantity	Item No.	Name	Quantity
	NO.41	090 weight plate guide sleeve	2			
	NO.42	Head weight stack	1			

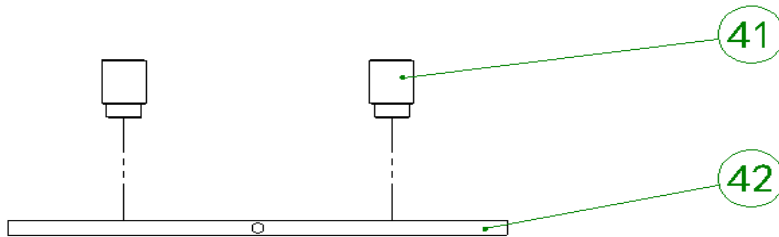

## Assembly steps

Step	Item No.	Name	Quantity	Item No.	Name	Quantity
5	NO.56	Cable	1			
	F	8*12 top wire	2			

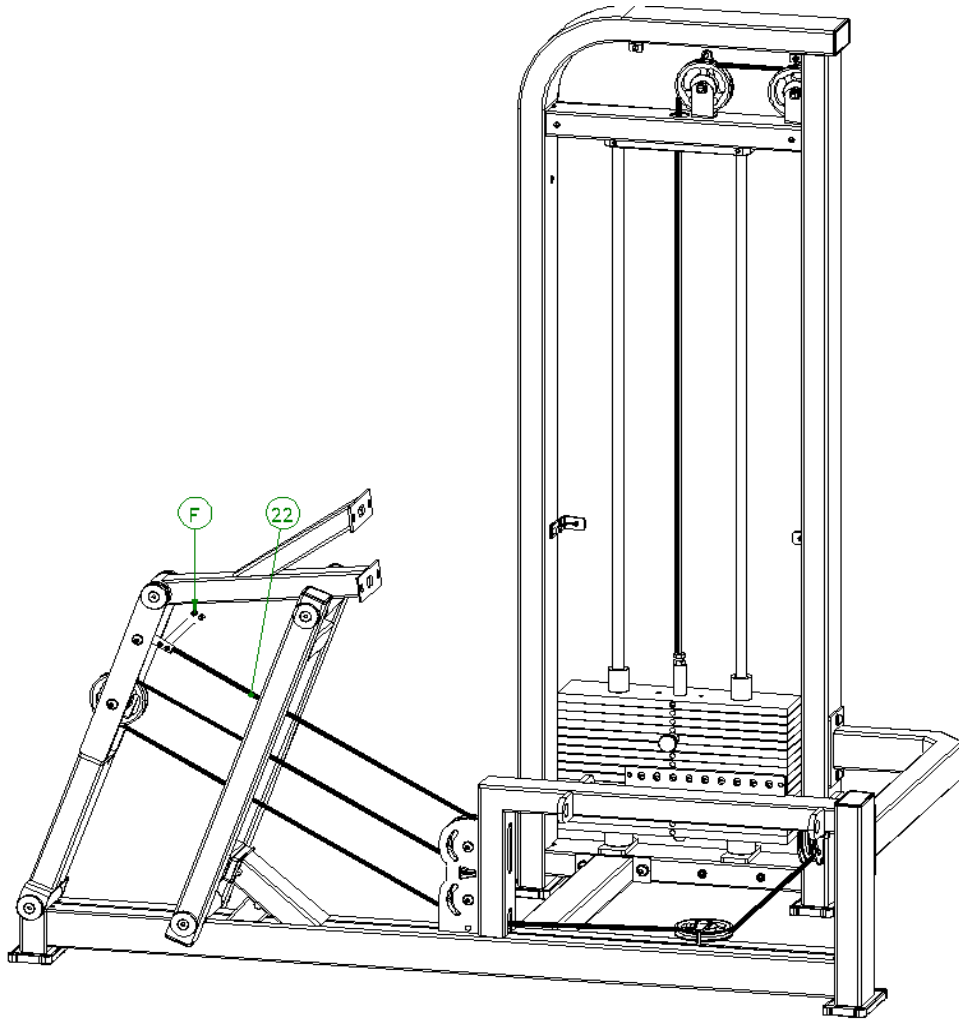

Schematic diagram of wire rope routing

## Assembly steps

Step	Item No.	Name	Quantity	Item No.	Name	Quantity
6	NO.22	Pedal welding group	1	B	Φ10 flat washer	4
				H	M10*20 flat head screw	4

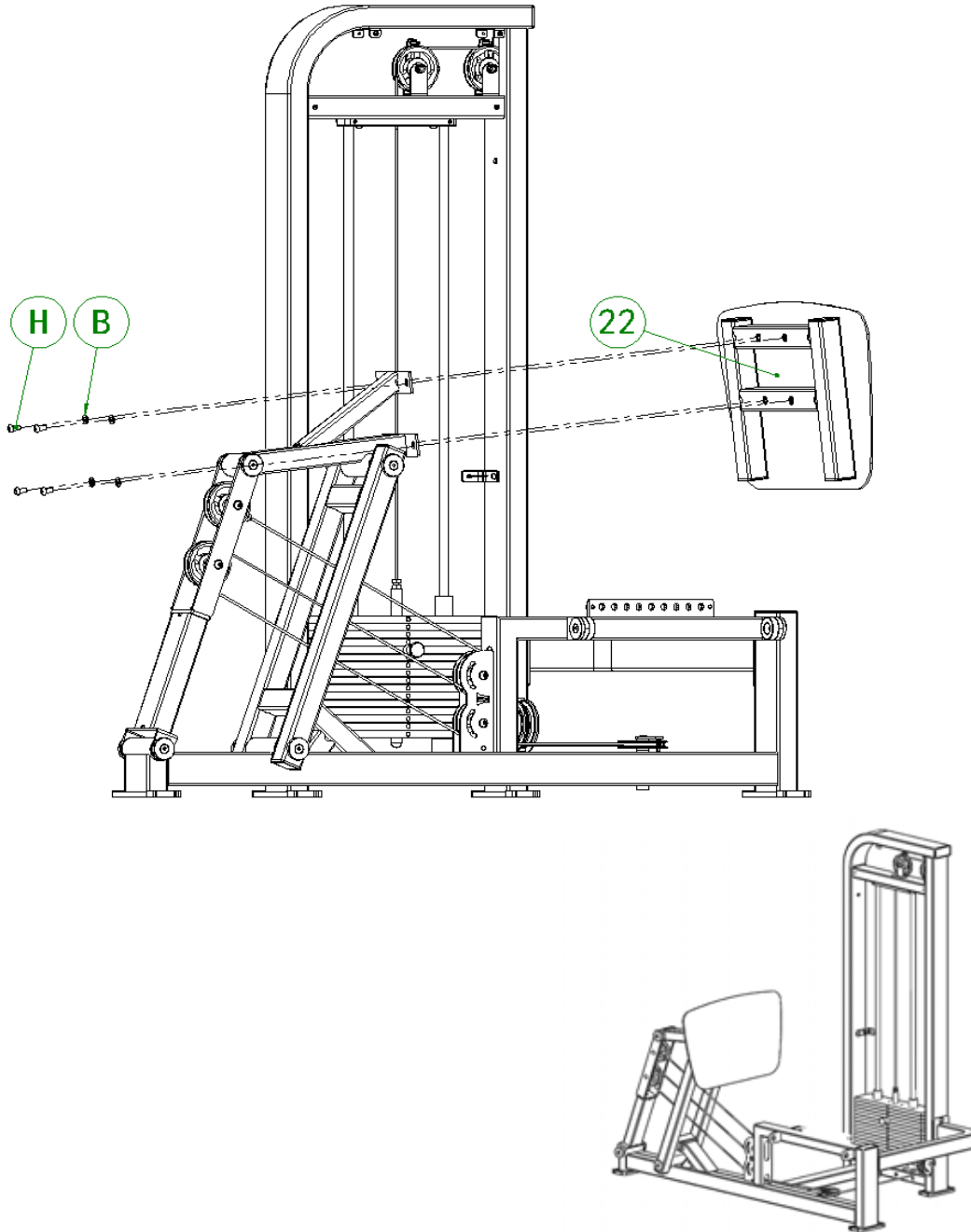

## NO.22 Pedal welding group\*1

Step	Item No.	Name	Quantity	Item No.	Name	Quantity
	NO.40	597 new square pipe plug 50*50	4			

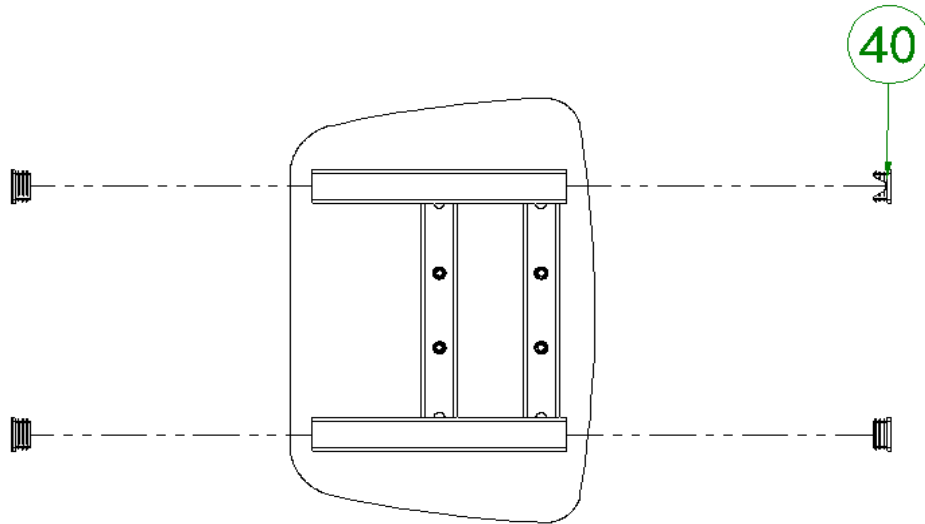

## Assembly steps

Step	Item No.	Name	Quantity	Item No.	Name	Quantity
7	NO.5	aluminum alloy flat end cap	4	C	M10*25 flat countersunk head screw	4
	NO.23	Round shock absorbing pad	4			
	NO.24	sliding axis	2			
	NO.25	Cushion back welding group	1			

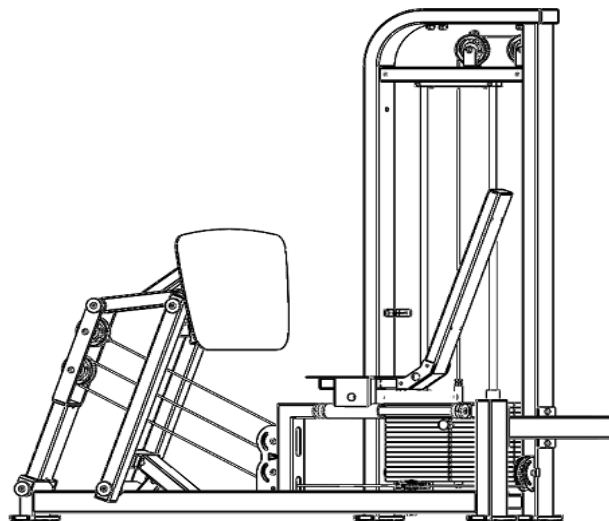
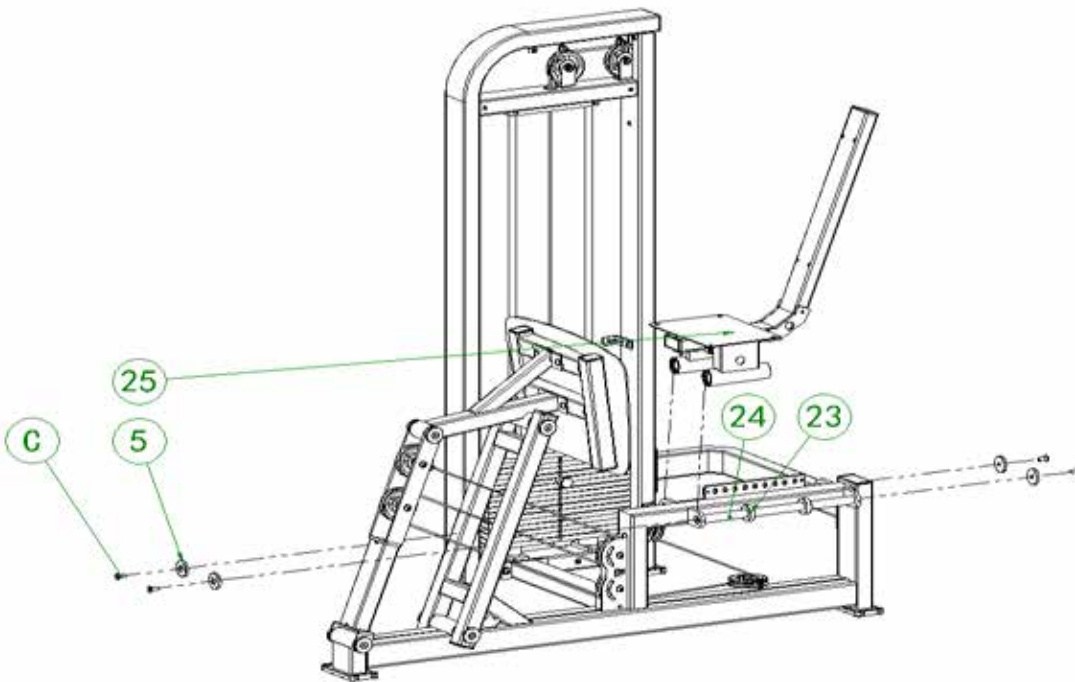

## NO.25 Cushion back welding group\*1

Step	Item No.	Name	Quantity	Item No.	Name	Quantity
	NO.43	596 new square pipe plug 40*80	2			
	NO.44	2006 pin (galvanized)	1			
	NO.45	Q1018-5029 aluminum alloy spring pin	1			
	NO.46	LM25UU linear bearing	4			
	NO.47	Φ40 hole card	4			
	NO.55	Q1001-5090 spring	1			

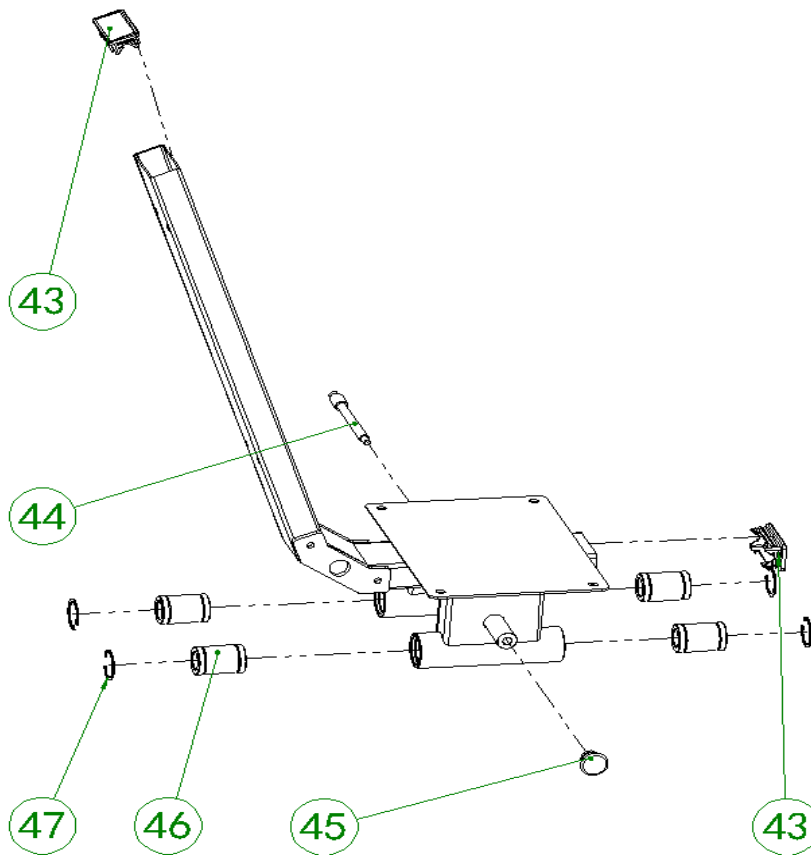

## Assembly steps

Step	Item No.	Name	Quantity	Item No.	Name	Quantity
<b>8</b>	NO.26	large backrest	1	I	M8*70 round head screw	4
	NO.27	Cushion back welding group	1	J	Φ8 flat washer	8
				K	M8*25 round head screw	4

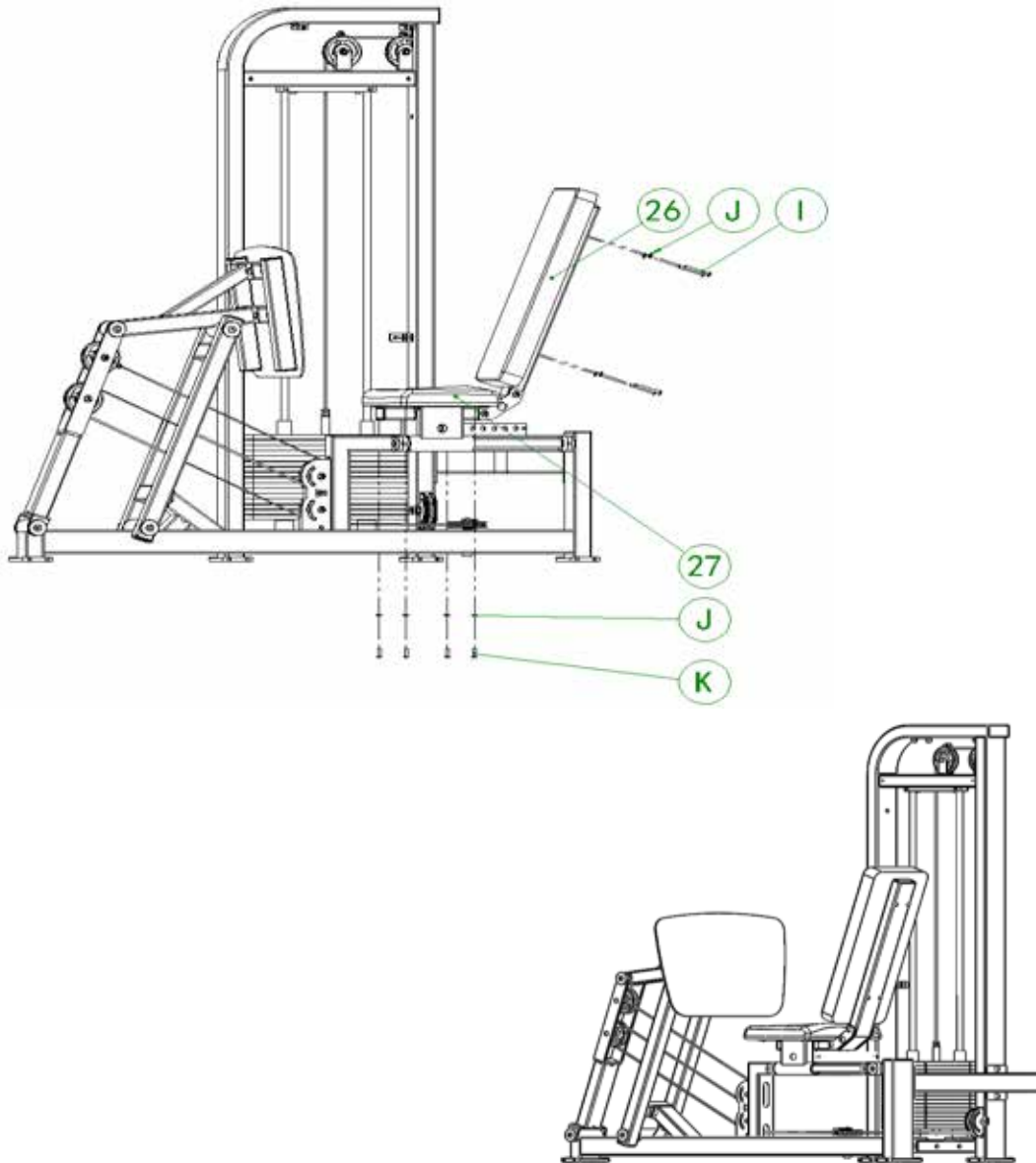

## Assembly steps

Step	Item No.	Name	Quantity	Item No.	Name	Quantity
<b>9</b>	NO.28	Label Edition	2	L	Cross recessed pan head screw M5*10	12
	NO.29	Cover	1	M	Φ5 flat washer	12

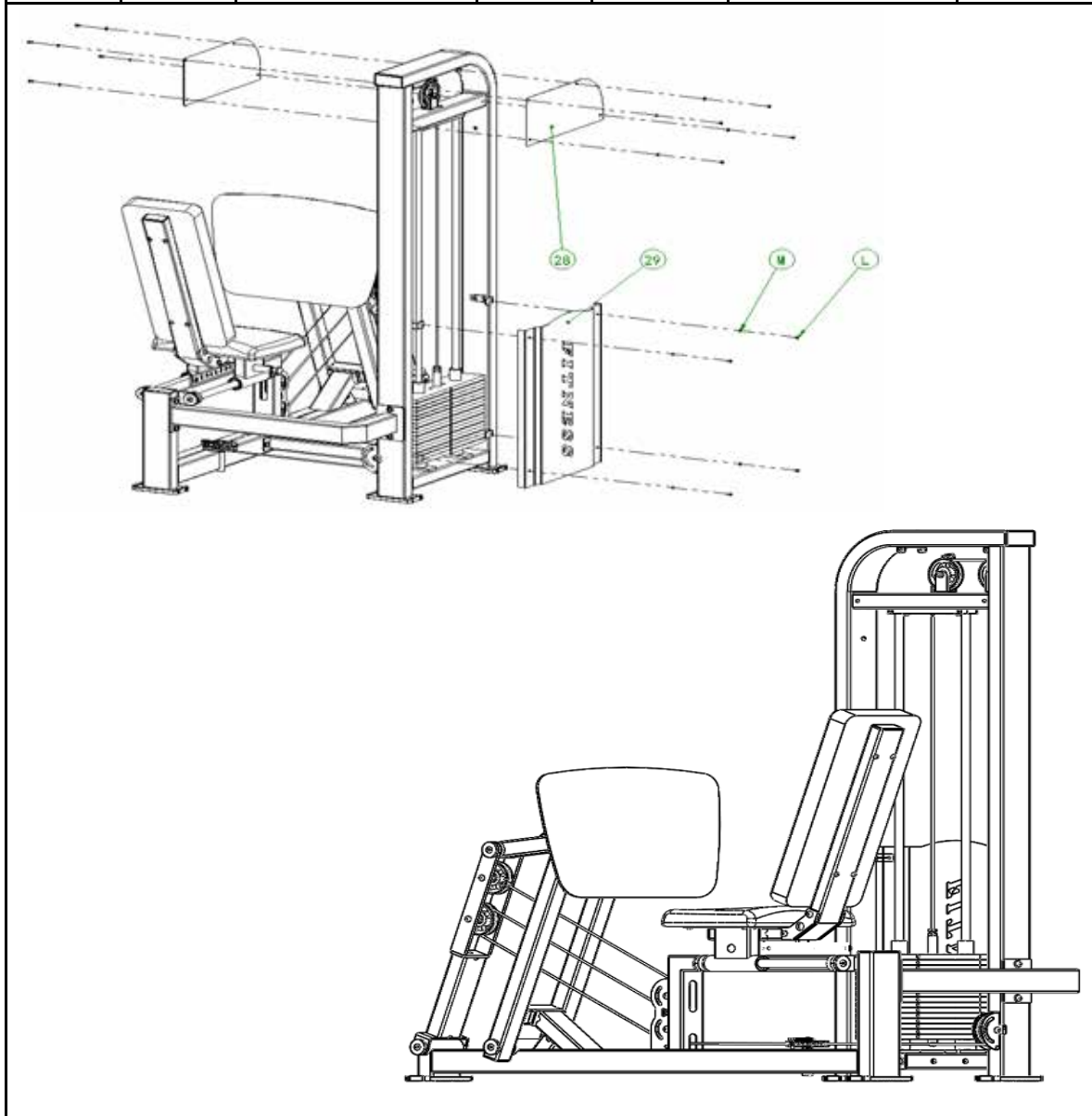

## Assembly steps

Step	Item No.	Name	Quantity	Item No.	Name	Quantity
	NO.48	Left handle welding group	1	B	Φ10 flat washer	4
	NO.49	Right handle welding group	1	H	M10*20 flat head screw	4

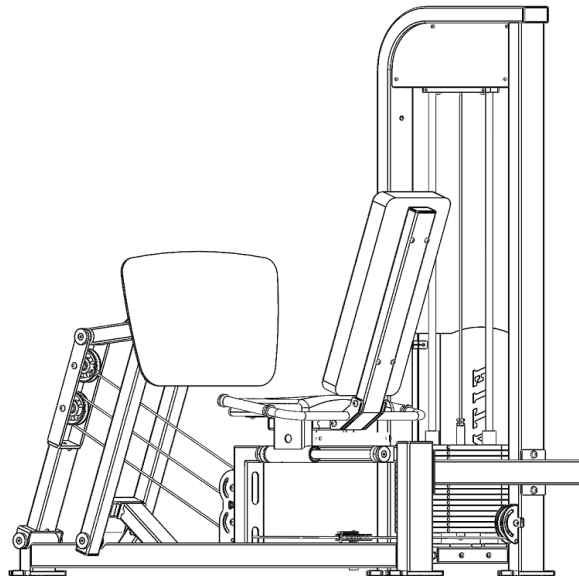
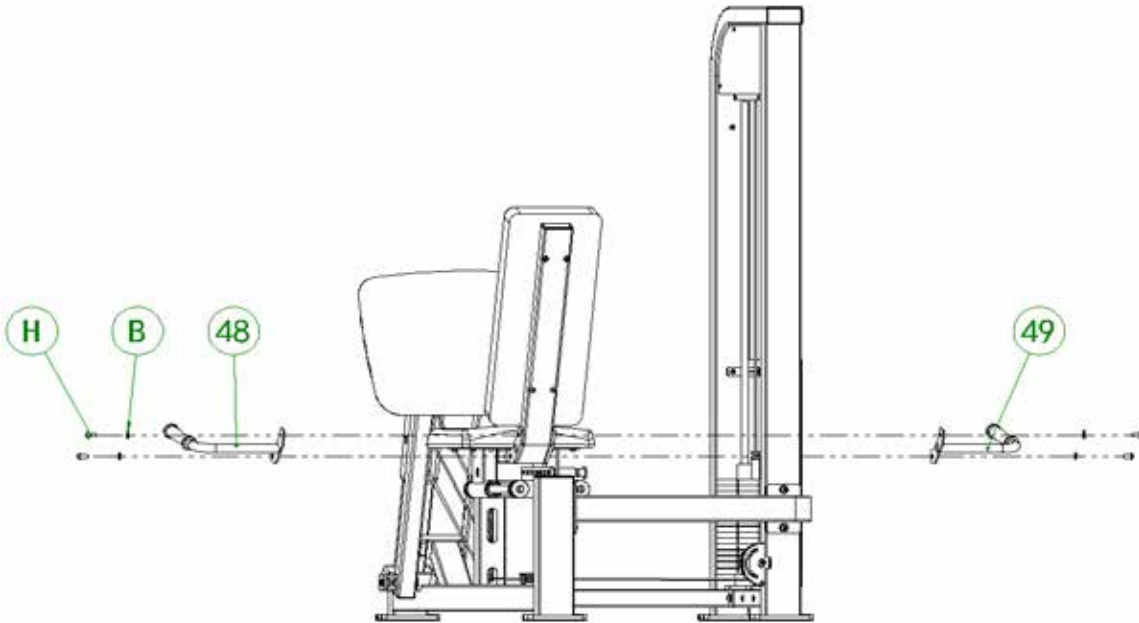

## NO.48 Left handle welding group

Step	Item No.	Name	Quantity	Item No.	Name	Quantity
	NO.50	2010 Aluminum End Caps	1	NO.53	0218 aluminum lock cover	1
	NO.51	2017 star nut M8	1	T	M8*25 flat countersunk head screw	1
	NO.52	Handle rubber 180mm	1	U	M5*6 top wire	2

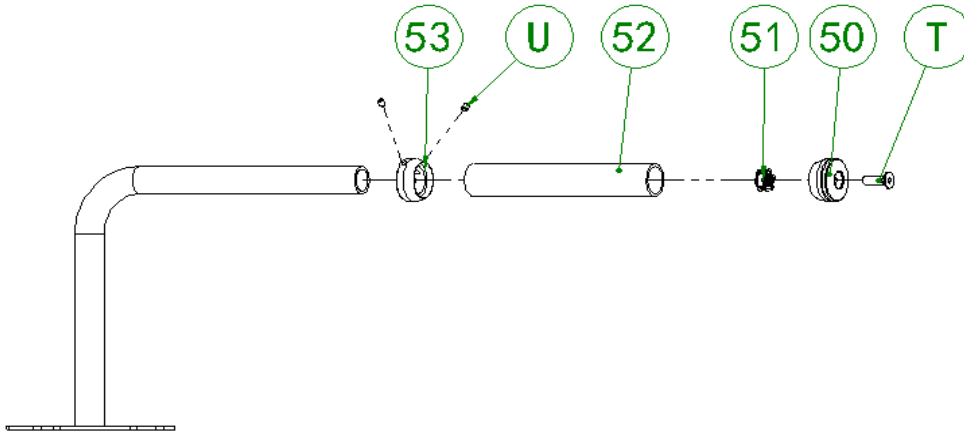

## NO.49 Right handle welding group\*1

Step	Item No.	Name	Quantity	Item No.	Name	Quantity
	NO.50	2010 Aluminum End Caps	1	NO.53	0218 aluminum lock cover	1
	NO.51	2017 star nut M8	1	T	M8*25 flat countersunk head screw	1
	NO.52	Handle rubber 180mm	1	U	M5*6 top wire	2

